

Wireless World

Radio • Electronics • Electro-Acoustics

34th YEAR OF PUBLICATION

OCTOBER 1944

MONTHLY COMMENTARY	289
GRAMOPHONE NEEDLE BUZZ By F. L. Devereux	290
IMPROVING INTER-CONTINENTAL COMMUNICATIONS By Thomas Roddam	295
LETTERS TO THE EDITOR	298
RADIO HEATING IN INDUSTRY	301
UNBIASED. By Free Grid	302
WAVE GUIDES (concluded) By Sqdn. Ldr. M. G. Scroggie	303
RANDOM RADIATIONS. By "Diallist"	307
CLASS "C" AMPLIFIERS By R. W. Hallows	309
WORLD OF WIRELESS	313
NEWS IN ENGLISH FROM ABROAD	314
BAIRD "TELECHROME"	316
"AESTHETICS OF SOUND REPRODUCTION" By H. A. Hartley	318
RECENT INVENTIONS	320

Proprietors :
ILIFFE & SONS LTD.

Managing Editor :
HUGH S. POCOCK,
M.I.E.E.

Editor :
H. F. SMITH.

Editorial, Advertising
and Publishing Offices:

DORSET HOUSE,
STAMFORD STREET,
LONDON, S.E.1.

Telephone :
Waterloo 3333 (35 lines).

Telegrams :
"Ethaworld, Sedist, London."

△

PUBLISHED
MONTHLY

Price : 1/6

(Publication date 25th
of preceding month)

Subscription Rate :
Home and Abroad
20/- per annum.

Branch Offices ;

COVENTRY :
8-10, Corporation Street,
Telephone : Coventry 5210.
Telegrams :
"Autocar, Coventry."

BIRMINGHAM :
Guildhall Buildings,
Navigation Street, 2.
Telephone :
Midland 2971 (5 lines).
Telegrams :
"Autopress, Birmingham."

MANCHESTER :
260, Deansgate, 3.
Telephone :
Blackfriars 4412 (4 lines).
Telegrams :
"Iliffe, Manchester."

GLASGOW :
26B, Renfield Street, C.2.
Telephone : Central 4857.
Telegrams : "Iliffe, Glasgow."

△

As many of the circuits and apparatus described in these pages are covered by patents, readers are advised, before making use of them, to satisfy themselves that they would not be infringing patents.

Exclusive features

of the
'STRATOSIL'
series of
**SEALED
VIBRATORS**

★ Owing to wartime restrictions on supply of raw materials, it is not possible to supply Wearite Components for purposes other than those connected directly with the war effort

- 1 All steel construction—even to the rivets—ensuring uniform expansion under extremes of temperature.
- 2 Reed driving coil—wound on a bakelite moulded bobbin to meet all climatic conditions.
- 3 Metal can, sponge rubber lined—Acoustically and electrically shielding the Vibrator.
- 4 Driving contact of non-tarnishable precious metal—ensuring starting under the lightest of pressures and voltages.
- 5 Contacts ground almost to optical limits.
- 6 Stack assembly. Mica and steel only are used.
- 7 Base sealed by the WEARITE STRATOSIL process.

Embodying "Oak Manufacturing Co.'s" patents 460470, etc.

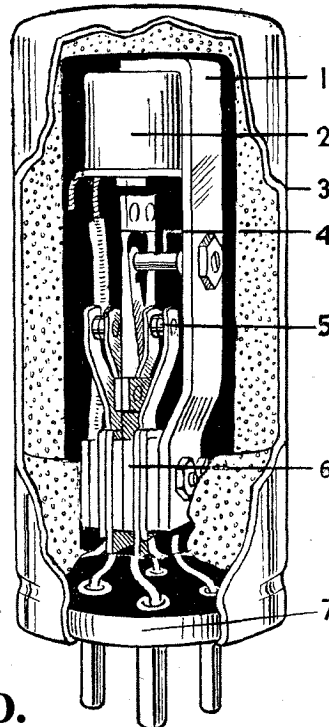

WRIGHT & WEAIRE LTD.

HIGH ROAD, TOTTENHAM, N.17.

Telephones : TOTtenham 3847-8-9



—and the roots go deep

Firm and enduring, the great tree stands, its roots spreading deeper and wider through the long years of steady growth.

So, too, have great industrial organisations like that of Philips grown and developed. The many Philips achievements and the high reputation of their products are rooted in persistent research, highly-qualified engineering

personnel, modern and efficient factories and long-accumulated knowledge and experience of the application of electricity to the needs of the modern world.

PHILIPS 
LAMPS ★ RADIO ★ X-RAY
COMMUNICATIONS EQUIPMENT
AND ALLIED ELECTRICAL APPLIANCES

PHILIPS LAMPS LIMITED, CENTURY HOUSE, SHAFTESBURY AVENUE, LONDON, W.C.2 (871)

Wireless World

Radio • Electronics • Electro-Acoustics

Vol. L. No. 10

OCTOBER 1944

Price 1s. 6d.

Monthly Commentary

Standards and Regulations

THERE is, we think, a moral to be drawn from a letter published in this journal last month, though the subject with which it dealt was perhaps rather trivial in comparison with the wider issues that will soon face the world of wireless. The letter in question was on the colour-coding of small resistors, of the type to be found in most kinds of wireless equipment. It was contended that the standardised significance given to the various markings is fundamentally wrong. The colour of the body, which is the most conspicuous, should indicate broadly the order of magnitude of resistance. By the existing code this is actually shown by the dot, which may in many cases be concealed. All the letters we have received tacitly accept the inherent soundness of our correspondent's proposal, but deplore any suggestion of a change to the improved system, maintaining that it would bring about endless confusion between resistors coded on the new and the old standards. In other words, it is too late to make a change. We can therefore assume with some certainty that the original standardising committee, the alternatives open to them, chose the wrong one. It is a chastening thought that thousands of man-hours throughout the world must have been wasted by such a minor lapse.

What is the moral behind this sad little story? Surely, that the most august standardising body, however representative, competent and conscientious it may be, is composed of fallible human beings, and that they are especially likely to make mistakes in dealing with a new art such as ours, in which the accumulated experience of earlier generations of workers is lacking. Steps should be taken to overcome this handicap by making the most of such experience as is available.

We submit that this can best be done by giving the widest possible publicity to any proposed form of standardisation or similar ruling before it reaches the stage where the decisions arrived at are irrevocable. Comments and criticisms should be invited from everyone likely to have anything to con-

tribute, and all rational suggestions should be investigated. Draft specification might sometimes be circulated to the technical Press.

The principle of encouraging free discussion and criticism at an early stage might be extended to embrace the regulations governing the general organisation of wireless services. A good example in this respect has been set us by the U.S.A., where senior officials of the Federal Communications Commission have recently put up for consideration by the American Institute of Radio Engineers a large number of the organisational problems with which the F.C.C. will have to deal after the war. Many of these problems are international in character, while others, though domestic, affect all countries to some extent. It is worth while giving a brief *résumé* of some of the matters that were thought worthy of special consideration.

Re-allocation of Frequencies

The opinion was expressed by an F.C.C. official, and will be generally agreed here, that the present allocation of bands for television (18 on U.S.A. standards) is quite inadequate for post-war requirements, and that at least twice that number is needed for complete national coverage. Similar demands were made for the extension of the existing 42-50 Mc/s band for FM broadcasting. Then the question of relay stations to link the television transmitters was raised, and it was considered that the possibility of extending these relay services to other countries should not be overlooked. In the field of domestic broadcasting on the medium band the problems are so different in America as compared with Europe there is little point in considering them, but in international short-wave broadcasting we come on to common ground. Here again there are bound to be important changes, though they will be dictated at least as much by political as technical consideration. The widest discussion of these and many other important matters should provide useful guidance for those who will frame our post-war regulations.

GRAMOPHONE NEEDLE BUZZ

An Inherent Form of Distortion : Possible Cures

WHEN standard commercial records are played through "high-fidelity" reproducing systems, the sensitive ear detects an irritating form of distortion which has been variously described by recent writers on high-quality pick-up design as "needle buzz," "acoustic buzz," "burring," etc. It is the sort of noise one would expect if the needle were loose in its holder or the needle tip not in continuous contact with both walls of the groove; but it persists after these obvious possible causes have been eliminated by close attention to the detail design of the pick-up.

What, then, is the origin of this distortion? It arises from the fact that the record is reproduced with a stylus the shape of which differs from that of the cutter which formed the groove in the original wax master. Whereas the cutting edges of the recording stylus are always in a plane at right angles to the average direction of the groove, the contact points between the groove walls and a

By F. L. DEVEREUX,
B.Sc.

to follow and there are simplifying assumptions which make it difficult to apply the formulæ quantitatively in practice. The factors involved can, however, be demonstrated graphically and it will be shown that not only is cross-modulation between the component frequencies of a complex wave inevitable with conventional needle shapes, but that the standard spherical point is incapable of tracing even a simple sine-wave groove without distortion. The trouble is worse with hill-and-dale recording, so we will start with this case to illustrate the origin of the distortion.

A sine-wave formed by a chisel-edged cutter on a hill-and-dale record is shown in section in Fig. 1 (a.) Imagine the spherical-pointed reproducing stylus to be stopped on the slopes half-way between hill and dale with its vertical axis coincident with the

behind original movement of the cutting edge. If we trace out graphically the path of the centre of the spherical point we shall find that it is not quite parallel with the record surface, though the difference from a true sine curve will hardly be detectable in the case of a long shallow wave as envisaged in Fig. 1 (a). With a sine curve of shorter wavelength and wider amplitude the distortion increases, and if the radius of curvature becomes equal to or less than the radius of the stylus point, as shown in Fig. 1 (b), the lower peaks of the resultant motion imparted to the stylus will be sharply pointed, while the upper peaks are more rounded.

In Figs. 1 (c) and (d) the stylus motion (dotted line) has been superimposed on the recorded sine-waves of Figs. 1 (a) and (b) respectively, and it is apparent that the distortion increases as the lateral displacement (or velocity) is increased relative to the linear displacement (or velocity). In practice this means that tracing

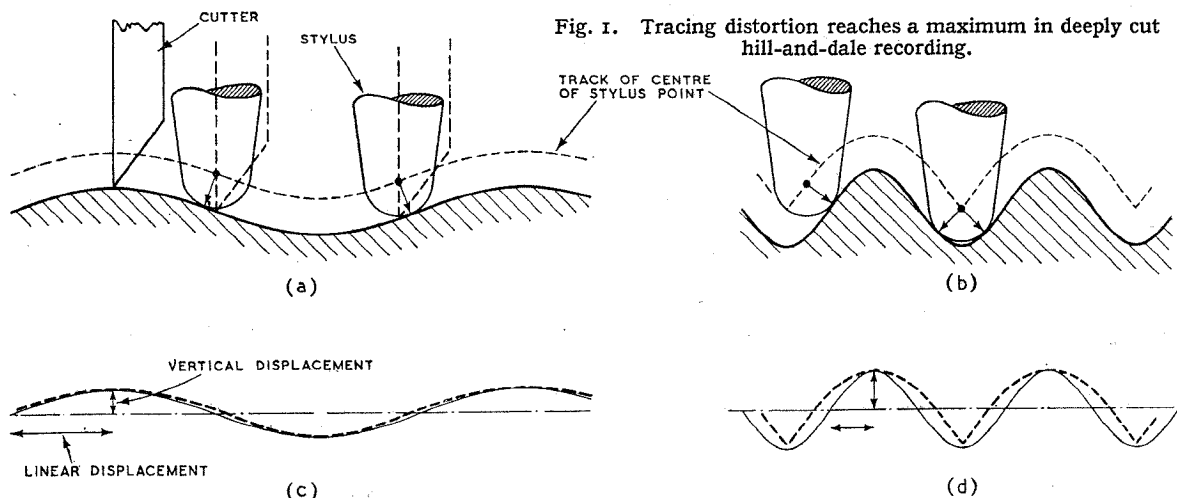

Fig. 1. Tracing distortion reaches a maximum in deeply cut hill-and-dale recording.

spherically pointed needle weave about and align themselves at right angles to the instantaneous direction of the groove. The waveform traced by the needle is never the same as that impressed on the record.

The theory of tracing distortion has been worked out in detail,* but the mathematics are not easy

position previously occupied by the leading edge of the cutter. The point of contact between record and stylus first leads and then lags

* "Distortion in Sound Reproduction from Records," by J. A. Pierce and F. V. Hunt. *Journal of Motion Picture Engineers*, Aug., 1938.

"Theory of Tracing Distortion in Record Reproduction," by W. D. Lewis and F. V. Hunt. *Journal Acoustical Society of America*, Vol. 12, Jan. 1941.

distortion will be at its worst on steep-fronted transients and at the inside of conventional disc recordings where the lowest linear groove velocity coincides all too frequently with the grand finale, fortissimo with full orchestra. The remedies are obvious—reduction of recording amplitude, increase of turntable speed, increase

of record diameter to avoid too small a radius at the inside of the groove.

In lateral-cut discs the tracing distortion is not as bad as in hill-and-dale, for (assuming a "good fit") the stylus point is driven in push-pull by both walls of the groove. Nevertheless, it can be quite considerable, as the curves of Fig. 2, based on calculations by Pierce and Hunt, show. The curves assume an amplitude of 0.002in. at 300 c/s, decreasing inversely with frequency above this point. In practice the high frequencies in orchestral recordings will contain less energy than the middle frequencies, so that the distortion picture will not be quite

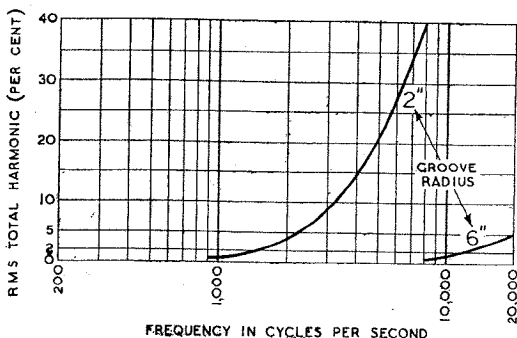

Fig. 2. Curve of tracing distortion, due to Pierce and Hunt, for inside and outside grooves of a 12-inch lateral cut disc. Speed 78 r.p.m., amplitude 0.002in \times 300/f, needle tip radius 0.002in.

as bad as it is painted in this figure.

The resultant lateral movement of the stylus contains the fundamental and odd harmonics when driven by a sine-wave groove. Even harmonics appear as vertical motion—the so-called "pinch effect" (*W.W.*, Sept., 1943, p. 262). Provision must be made in the pick-up for this vertical motion if the stylus is to ride in continuous contact with the groove walls, and since the vertical vibration frequency is never less than twice the lateral frequency, the designer is presented with quite a problem in placing the vertical resonance where it can do no harm. It is difficult enough to raise the armature resonance into the 10,000 c/s region and, although in conventional types, one can design the armature shape for minimum radius of gyration about its horizontal axis, in a vertical direction the inertia is provided by the full mass of the armature assembly. One way of overcoming this difficulty is suggested in Fig. 3 (b), where a stylus point of minimum mass is carried on a light, springy

extension of the main armature, which should preferably be arranged to rotate about a vertical axis.

The argument so far has been restricted to the tracing of pure sine-wave grooves. When two or more frequencies are recorded simultaneously, tracing distortion results in intermodulation, which gives rise to sum and difference frequencies bearing no harmonic relation to the original fundamentals. The ear is far less tolerant of these inharmonic distortion products than of straightforward harmonic distortion, and there is little doubt that they are the main constituents of "buzz."

The mechanism of intermodulation arising from the use of a spherical-pointed stylus should be clear from an inspection of Fig. 4,

which shows an enlarged plan view of one cycle of a 300 c/s note as it would appear if recorded at maximum amplitude on the inside grooves of a disc. Superimposed on it is a 6,000 c/s note of equal energy content. Let us assume that the combined wave is traced by a spherical needle of such a size that it makes contact with the walls at the top of the groove. At position A one side of the needle is on a ridge and the other in a furrow of the 6,000 c/s wave,

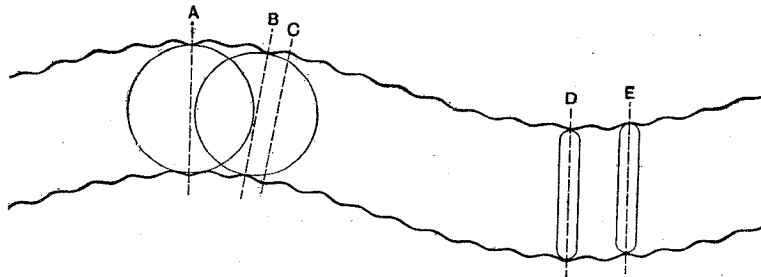

Fig. 4. Illustrating the origin of cross-modulation between 300 and 6,000-cycle waves recorded simultaneously at maximum relative amplitude on the inside groove of a lateral-cut disc.

which is more or less faithfully reproduced in the lateral movement of the stylus. At position B the contact points are both on

ridges and at C in furrows of the 6,000 c/s wave, so that the stylus merely moves up and down and there is no 6,000 c/s lateral movement at all. A few cycles further on the conditions of position A are repeated and 6,000-cycle lateral movement is again imparted to the stylus—and so on. It is also interesting to note that in passing

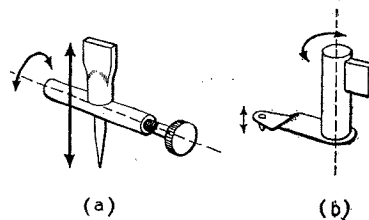

Fig. 3. (a) Conventional pick-up movement. (b) Redesigned movement with reduced inertia for vertical motion.

from A to B the upper contact point has traversed two wavelengths, while the lower contact has moved only one and a half wavelengths along the 6,000-cycle wave. The complexity of the resultant movement of the stylus can be more easily imagined than calculated—and this is for the simplified case where a large-diameter stylus makes contact only in one plane corresponding with the top edges of the groove. With a standard needle having a tip radius of the order of 0.0025in. the contact points will ride up and down the walls of the groove tracing lines of varying relative phase and in three dimensions. A scale model is the only practical way of studying the exact behaviour of the needle in the groove; it is sufficient for our present purpose to realise that

whereas the 300 c/s note may be well represented in the output, the 6,000 c/s note puts in only an occasional appearance in varying

Gramophone Needle Buzz—phases through a "buzz" of cross-modulation products.

Some reduction in cross-modulation products is obtained by using a needle or stylus with a tip radius equal to the radius of curvature of the bottom of the groove. The snag here is that with conventional methods of record manufacture there is a tendency to fill in the fine texture at the bottom of the groove owing to unequal deposition of metal in the electro-plating processes. One thing is certain, if we are to continue to use spherical-pointed needles—and there is no denying their convenience—it is a waste of time to strive for clear quality with an extended frequency response on all types of records unless there is a drastic revision of groove size, needle dimensions, and the record manufacturing

which are the more irritating constituents of the "buzz."

For those who do not give up so easily, there is the more exciting possibility, suggested by B. J. Olney, of attacking the distortion at its source by using special needle tips of other than spherical shape. Referring again to Fig. 4, if we could use a thin lamination, say, one-thousandth of an inch in thickness as a stylus mounted always at right angles to the mean axis of the groove, as shown at positions D and E, the original movement of the cutter would be more faithfully reproduced. The difficulty is to devise a practical interpretation of this ideal, since diamond or sapphire laminations thin enough to reduce the distortion would not be strong enough to stand up to ordinary handling, and might not even be able to sustain the forces due to frictional

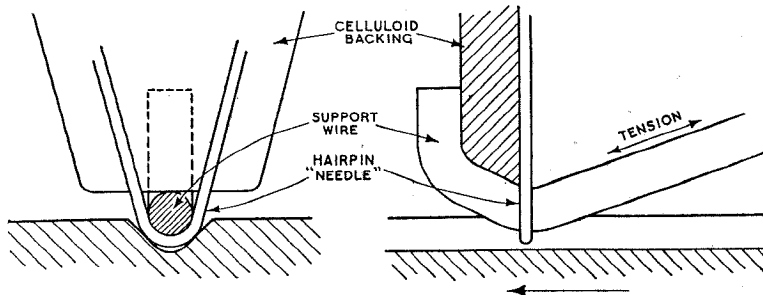

Fig. 5. Essential details of proposed "hairpin" needle.

process. The system of embossing the groove with a stylus of the same form as that used in the pick-up would seem to offer the most promising solution.

In the meantime what are we to do with our existing libraries of records? The first step—obvious and rather dull—is to sort them into two categories, the soft, smooth types with low amplitude/linear displacement characteristics, and the loud "edgy" variety with aggressive transients and turgid orchestral climaxes. The first group can be given the full frequency response of which the pick-up, amplifier and loud-speaker are capable, in the hope (not always justified) that new beauties of tone may be revealed. The second (and larger) category must be muzzled as far as possible by means of a low-pass filter cutting off at 6,000, 5,000, 4,000 c/s, or whatever frequency is found necessary to suppress the high-order cross-modulation products

drag along the line of the groove. Even if the middle section were thickened to form a backbone there would still be the possibility of chipping at the edges due to grit, a frequent occurrence with recording cutters.

A tough metal would seem to be the answer, and as there is no immediate prospect of new types of needle appearing on the market it is up to the reader to try his hand at making some for himself. With the aid of a pair of tweezers, a watchmaker's magnifier and a steady hand, this should not prove to be beyond the ability of the amateur mechanic. The proposed form of construction might be adapted to existing pick-ups but is better incorporated in a movement of special design, since it offers the possibility of reducing the inertia of moving parts to an unprecedented low figure.

The thin "edge" may conveniently consist of a hairpin of fine wire, at right angles to the

groove, bent round another wire running in line with the general direction of the groove (Fig. 5). Nickel-chrome or nickel-iron resistance wire should be suitable for the hairpin on account of its

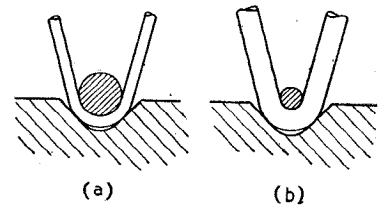

Fig. 6. Alternative choice of wire gauges giving needle radius of 0.003in. (a) 42 and 50 SWG. (b) 47 and 47 SWG.

hardness compared with copper and also its ability to take a layer of chromium plating if this should be found desirable to improve wear and reduce friction. The support wire will serve as a tension member to resist the frictional drag of the record, and soft copper may be used here with advantage since it is more or less self-damping and will be less resonant under working conditions. To prevent the hairpin being dragged off the support wire a backing of celluloid film about 0.005in. thick is provided and the whole assembly is fixed with a cement made by dissolving pieces of the film in acetone or amyl acetate. As an additional precaution the two wires could be spot-welded where they cross by discharging a reservoir condenser through the junction. The celluloid film above the needle may take any desired form and can be used to drive a miniature Stalloy armature, moving coil or bifilar movement.

The choice of wire gauge for the needle elements is important. To

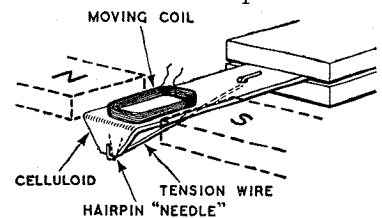

Fig. 7. Simple moving coil pick-up using the hairpin needle principle.

ensure a good fit between needle and groove the outside radius of the hairpin should be 0.003in. and this will be obtained by wrapping a 50 SWG (0.001in. diameter) wire round 42 SWG (0.004in.) or

47 SWG (0.002 in.) round 47 SWG. These alternatives are shown at (a) and (b) respectively in Fig. 6. The ideal arrangement is obviously (a) since it gives the smallest radius of contact with the groove, but 50 SWG wire is not readily obtainable, is difficult to handle without breakage and will wear through quickly—possibly before the end of one record—if it is not chromium plated. The 47 SWG wire will give more tracing distortion but is still much better than a standard needle when new; even after wear the width of the “flats” can never exceed 0.002 in. It is easy to handle and is recommended for preliminary trials; old wirewound resistances of high value are suggested as a source of supply.

It is not easy to bend hard re-

nifer the distance it descends into the gap.

Having manufactured a small stock of hairpins and cut the sides to equal length, the pick-up movement should be turned upside down when a hairpin can be balanced astride the support wire and shaken or brushed up to the celluloid support, where it is fixed with cement. Several attempts will probably be necessary before the first needle is successfully made; the hairpins, like their larger prototypes, have a mysterious habit of disappearing.

The writer had got as far as playing half a dozen records through with one of these needles in the pick-up design shown in Fig. 7, and although the improvement in quality was most promising, examination under a micro-

in the groove is not more than two or three grams; (b) chromium plating the hairpin wire.

A possible design for minimum weight is suggested in Fig. 8, in which a minute triangle of celluloid is supported through holes in the corners by a “spider’s web” of wires arranged to give lateral rigidity at the top of the triangle with freedom of movement at the bottom point to which the tension support wire and hairpin needle are fixed. Record vibrations are translated into up-and-down movement of the wires on each side of the web which are connected in series and work in slots in a soft iron pole-piece system to form a single-turn moving coil. A high flux density and low resistance in the coupling transformer primary should effectively damp

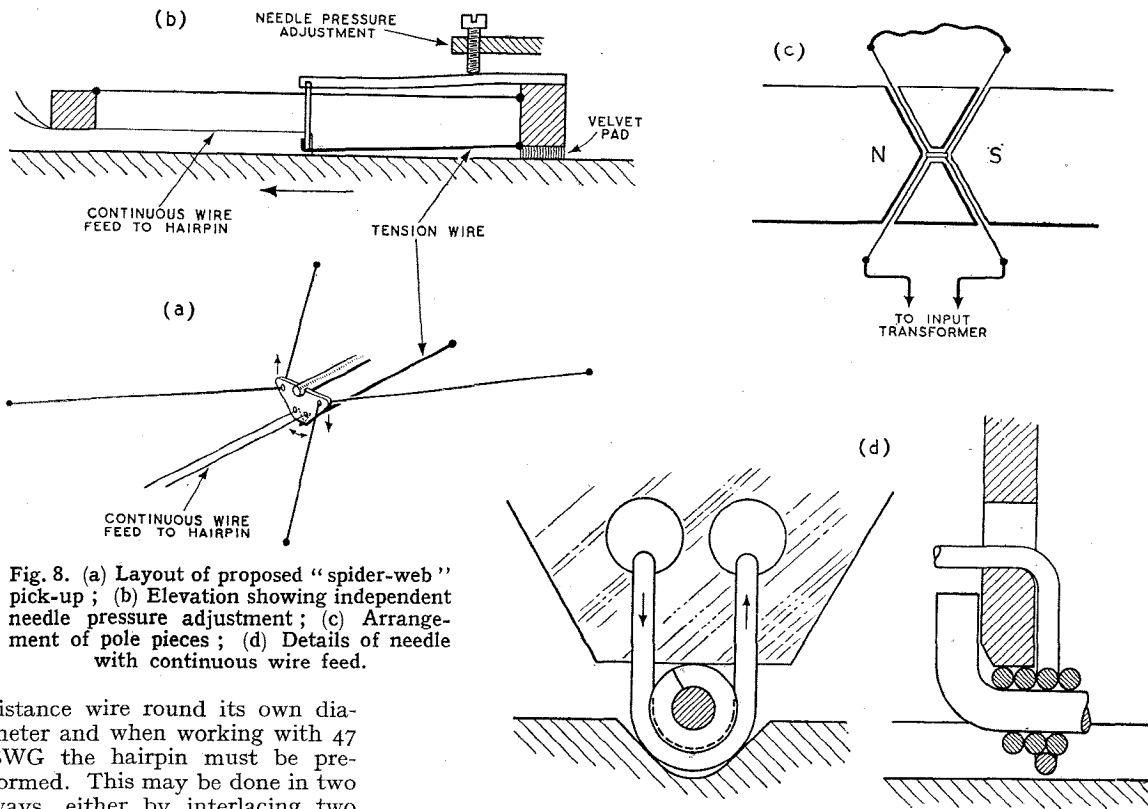

Fig. 8. (a) Layout of proposed “spider-web” pick-up; (b) Elevation showing independent needle pressure adjustment; (c) Arrangement of pole pieces; (d) Details of needle with continuous wire feed.

sistance wire round its own diameter and when working with 47 SWG the hairpin must be preformed. This may be done in two ways, either by interlacing two loops of the wire and pulling until one loop breaks, or dulling the edge of an old razor-blade on an oilstone and pressing it across the wire, which is laid on a block of hard rubber. The correct radius of curvature on the razor-blade edge can be judged by opening a micrometer to 0.002 in., and inserting the tapered edge of the blade and noting through a mag-

scope showed that the wear with a needle pressure equivalent to 20 grams was considerable—half the diameter of the wire, in fact. Other duties have prevented further pursuit of the matter, but it is hoped to overcome the wear problem (a) by reducing the inertia of moving parts to fly-weight proportions so that the pressure needed to hold the needle

out any tendency to “stretched-string” resonance.

If the expected reduction in needle wear is obtained it might be possible to incorporate a continuous feed for the hairpin wire, thus solving the problem of needle changing. The criterion for success will be whether the wire, after the wear of one side of a 12-inch record, has enough sectional area

Gramophone Needle Buzz—

left to withstand the pull required to bring a new length of wire into position. In the absence of a cemented or welded joint some sort of groove would also be necessary to hold the hairpin wire against the drag of the record. This might be provided by over-winding a 47 SWG core with a tight coil of 50 SWG—after the manner of a loaded piano string—and using 50 SWG for the continuous feed to the hairpin Fig. 8 (d). With this arrangement the pick-up head would have to be skewed slightly to compensate for the slight "screw-thread" angle imparted to the groove between adjacent turns of the coil.

Such a light suspension is, of course, quite incapable of tracking the pick-up across the record or dealing with the swing from eccentric centre holes. A simple way out of this difficulty is to fix a strip of velvet or plush on the underside of the pick-up before the needle (looking in the direction of rotation of the record). This will take the main weight of the pick-up head, clean grit from the grooves and, by alignment of the bristles in neighbouring grooves, provide enough grip to track the pick-up towards the centre of the record. The strip should be about $\frac{3}{8}$ in. wide and should extend about $\frac{1}{2}$ in. on each side of the needle so that the latter is dragged into the starting groove at the outside and pushed off at the inside of the record. Vertical needle pressure is then applied independently of the pick-up weight by an adjustable leaf spring or wire pressing on a notch at the centre of rotation of the celluloid triangle.

In conclusion, a note on chromium plating may be helpful. The bath for the hardest surface (as used in toolmaking) should consist of 25gm. of chromium oxide (CrO_3) dissolved in 100 c.c. of water and acidified with 0.25 gm. sulphuric acid (0.4 c.c. of accumulator acid, specific gravity 1.35). The working temperature should be kept close to 40 deg. C. and the anode should be of lead. A high current density gives increased hardness—possibly due to the adsorption of hydrogen which is evolved in large quantities at the cathode. Exact figures for current cannot be given owing to the difficulty of assessing area, but

Wireless World

excessive current is indicated by the formation of nodules on the surface of the work. It is important not to break the current while the work is being dipped. There is no need to clean the surface as the solution has a powerful degreasing action. Avoid inhaling the fumes, which are poisonous.

INTERNATIONAL RADIO LANGUAGE

THERE has of late been some discussion in amateur transmitting circles as to how the language problem can best be overcome when work is resumed after the war. Naturally, Basic English is widely advocated, but several "coined" languages have their supporters. The latest suggestion is for the use of "Interglossa," the auxiliary world language evolved by Lancelot Hogben. Being based on word-roots widely used in science, it has the particular advantage, as a medium of communication between wireless men, that many of the words will be already familiar to them; the technical vocabulary of any new art such as ours tends to become to a large extent international.

The suggestion for the use of Interglossa comes in a letter published in the *R.S.G.B. Bulletin*,

which is reproduced here by permission of the Editor.

I have been most interested in your comments, and readers' letters, on Basic English. I have been familiar with Esperanto for some years, and next to amateur radio, my favourite hobby is philology, particularly with regard to auxiliary languages. English, with its wealth of literature far above that of any other natural language, would be the best international language, but with its phonetic and grammatical inconsistencies has little chance of wide acceptance in our time. Basic English tenaciously retains the worst characteristics of English.

As an auxiliary, Esperanto, with all its faults, is at least consistent, and has the great advantage of already having a following, and a ready-made organisation for its propagation. "Basic" Esperanto could be learnt in a few weeks, but an even shorter time need be spent in learning sufficient "Interglossa" for amateur requirements. The latter auxiliary (Interglossa, Pelican Books, by Lancelot Hogben) is by far the most scientific so far, and the amateur will find that a great number of the roots are already known to him. The component parts of a sentence go together with the ease of the components of a TRF receiver, and the result cannot be ambiguous.

Amateurs who are interested in the whole question of languages could do worse than read "The Loom of Language," in the same series as "Mathematics for the Million."

VARIAN J. WILSON (ZL3DU),
R.N.Z.A.F.

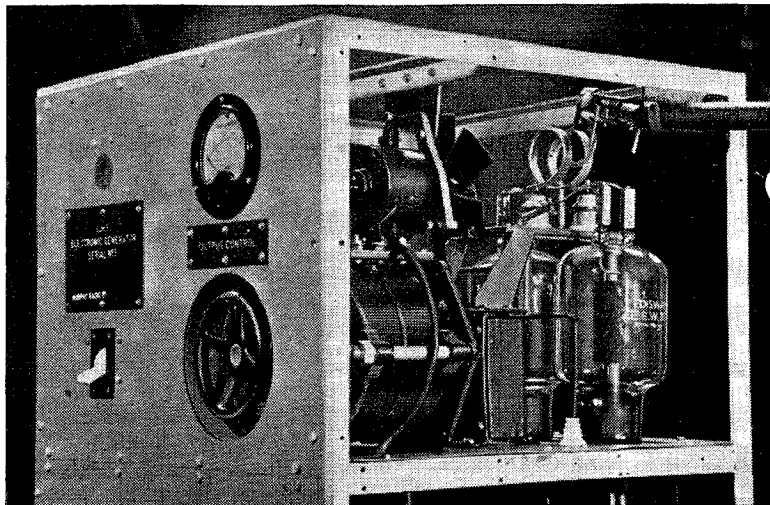
MURPHY UHF ELECTRONIC GENERATOR

DESIGNED as a universal oscillator for all types of small scale radio heating, this recent product of Murphy Radio, Ltd., Welwyn Garden City, is rated for a power input of the order of 1kW. It operates at a frequency of 80Mc/s. The photograph shows the top half of the unit with screening

panels removed. The two-turn oscillator coil bridges the anodes of the valves, and a single-turn coupling coil is connected directly to the co-axial feeder cable.

Power supply for the anodes is at 3,000V derived through mercury vapour rectifiers and smoothing filters housed below.

Improving

INTER-CONTINENTAL COMMUNICATIONS

Making the Best Use of Available Frequency Bands

POST-WAR international trade is one of the most popular stamping grounds of the present-day politician, though some of the arguments in its favour are hard to follow, and even the economists appear to disagree on the details. However, it seems certain that we must have international trade; it is equally certain that, if we are to have a tremendous outburst of trading, we must have plenty of telephones. Most of us have learned during this war that the only way to get anything done is to speak, either face to face or by telephone, with the man who will do the job. Letters seem only to set files in motion, and not machines.

To both British and American engineers international radio telephony is initially a problem of local continental telephony and then of inter-continental telephony, with transatlantic telephony ranking very high in the problems of inter-continental traffic. The European capitals are joined by a multiplicity of short-range links, as are the centres of population of the Americas. To join Europe and America is the first problem. A similar problem, with probably a different solution, is provided by the vast expanse of Russia. The Europe-America link is, however, more interesting technically, involving as it does some 3,000 miles of sea.

As things stood at the beginning of the war a service was provided by direct short-wave transmission using single side-band and directional transmission and reception techniques, together with a long-wave channel for use when propagation conditions were unfavourable. The principal defects of the short-wave systems were the propagation difficulties which sometimes occurred, plus a certain amount of "traffic anarchy" which leads

By THOMAS RODDAM

Suggestions for operating a world-wide short-wave communication network planned on the lines of the proposed "Equatorial Radio Girdle" described in *Wireless World* for May 1944

to inefficient use of the load-handling range of frequencies available. If traffic is to increase, the maximum use must be made of the very limited band-width at our disposal.

Increasing Traffic Capacity

Various solutions have been proposed, and two are of particular interest. The Vocoder, which provides a means whereby ten speech channels can be compressed into the space of one, provides a means for the transmission of intelligible speech. Unfortunately, the writer has not had the opportunity of hearing this device in action. Private reports, however, suggest that for communication between strangers on business matters it would be excellent: where more subtle shades of meaning were being expressed, the impersonality of the system is an obvious disadvantage. It is difficult to assess the economic aspect of this: although ten channels occupy only the space of one, ten sets of Vocoder equipment and ancillaries would be needed. Hence the Vocoder channels could not cost much less (if any) than normal channels. For those who do not remember the system, the Vocoder is a device which classifies the speech sounds applied to its input, both as regards pitch and harmonic content, and transmits code messages describing

the sounds to the decoding device which reproduces the appropriate noises in accordance with the code description. Obviously, it is too much to hope that absolute fidelity can be obtained by such means.

The second proposal to receive strong support is the cable with submarine repeaters. In one description of such a scheme, two cables, each with 47 repeaters at 42-mile intervals, would provide a 48 kc/s bandwidth between Newfoundland and Great Britain. The repeaters are $1\frac{1}{2}$ in. in diameter inside, and have a total length of seven feet. They can be bent round a six-foot cable drum. A reasonable requirement for the life of the repeater without any replacement of parts is quoted as 20 years. The President of the Bell Telephone Laboratories, in describing the system, stated that the life and maintenance problem was principally a valve problem. To the writer, in the less rarefied air which surrounds the laboratory and the factory, dry joints, fluke component faults and inspection errors rank high, and the idea of such a system is rather a nightmare. One Government inspector, in a factory recently visited, was asked at lunch his feelings if asked to pass a unit with an implicit guarantee of such perfection. He expressed considerable doubt about the possibility of getting the required certainty, and expressed it with the vigour for which the race of inspectors is well known. If repairs are made in mid-ocean it appears to the writer that an improbability becomes an impossibility. In any event, the cable is a brute force solution, and does not provide a satisfying answer to the general problem of enabling any two telephone subscribers anywhere to converse at any time of the day or night.

Inter-continental Communications—

It is always tempting, and more especially so when there is no immediate prospect of having to do more than speculate, to prophesy grand and elaborate schemes for providing links with very short wavelengths between everywhere and Erewhon, with

The use of submerged repeaters inserted at intervals in long-distance submarine telephony cables is mentioned in this article as an alternative to wireless for transoceanic telephony. This photograph shows the inner assembly of a three-stage valve repeater recently fitted by the G.P.O. midway in a 44-mile telephone cable in the Irish Sea. With the help of

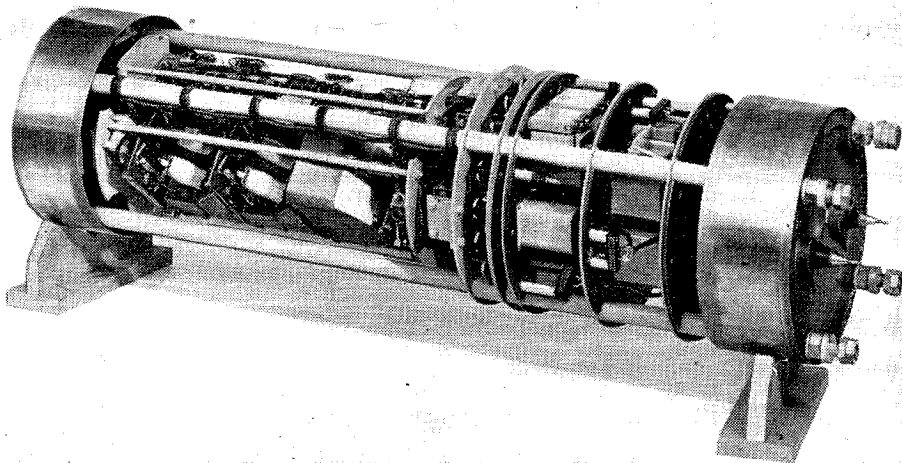

the repeater the cable transmits a frequency band-width of 192 kc/s, providing 48 telephony channels. A dielectric failure developed in a mica filter condenser five months after the repeater was laid, necessitating its replacement. But, according to the *P.O. Electrical Engineers' Journal* (by courtesy of which this illustrated description is published), "although this failure was unfortunate, it cannot be regarded as having any great significance in connection with future development."

unattended repeaters at every street corner. The drill is to reason thus: before the war we had a link across the Channel on 17 cm. If at 40 Mc/s the bandwidth of 2 Mc/s for television could be handled, on 2,000 Mc/s (15 cm.) we should be able to transmit a bandwidth of 100 Mc/s. This would provide some 10,000 very high quality telephone channels. For transocean work automatic repeaters which propelled themselves to maintain their defined positions can be envisaged. But it all seems rather fanciful as a programme for the next twenty years.

The idea that all immediate needs can be met by careful use of the HF band does not seem unreasonable to the writer. If we accept the idea of a world girdle, or better, the girdle following roughly the tropic of Cancer shown in the map published in the May, 1944, issue of *Wireless World* and a Capricorn girdle based on Rio de Janeiro or Buenos Aires, Capetown, Melbourne or Singapore, it does not appear extravagant to assume that between

any two master longitudes there will be a 6-Mc/s wide communication channel available at any time of the day or night. Indeed, such a system could probably be arranged entirely between points in the British Commonwealth and Empire, and thus be controlled by a single administration without

a television plus film system of typescript transmission, though at first it seems faster than a printing telegraph system, is in fact inherently slower. For a printing telegraph to transmit a single letter it must send five signals: for a television system five signals will not be nearly enough.

the complexities which international organisations always seem to involve. The handling capacity of such a bandwidth is 60,000 words a second in printing telegraph systems, 1,500 normal telephone channels or a theoretical figure of 37,500 words a second in the reported Baird project of televised typescript. It is worth digressing here to point out that

Assuming that 6 Mc/s is in fact the bandwidth available, an arbitrary division into telegraph and telephone channels can be made. A typical figure would be 480 telephone channels and two million words a minute. This leaves quite a lot of space for traffic concerned only with the maintenance of the system. It also assumes that each message traverses the whole sys-

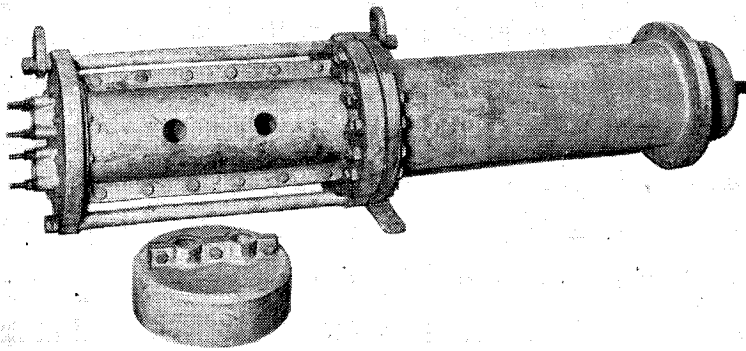

Courtesy: *Post Office Electrical Engineers' Journal*

Outer case of the submerged repeater, which is laid in comparatively shallow water at a depth of some 200 feet and has to withstand a hydrostatic pressure of 93 lb. per sq. in. Repeaters envisaged for transoceanic work would, of course, be designed to work at much greater pressures.

tem, although in fact it may only use 45° of the whole 360°. Only an operating company can make anything but a wild guess at the true figure and best distribution.

To examine the engineering practicability of such a scheme it is necessary to see how it dovetails into existing practice. The 12-channel carrier system forms the most convenient standard element with which to commence. This system is widely used for transmitting over open wire lines and simple cables. The channels are spaced at 4,000 c/s intervals,

blocks based on its traffic needs, and subject to periodical revision. If the charge made by the girdle organisation for each block increases as the number of blocks increases, countries will quickly forget that their national pride requires an extra block which cannot be adequately loaded. It is assumed also that some administrations will cover several states—in the Balkans perhaps. Assume, then, that between London and the Canaries there are ten blocks allocated to girdle traffic, between Rome and Alexandria one block,

passed. The system is shown in block schematic in the diagram.

Frequency Changing

The incoming blocks are amplified and monitored, and then passed to modulators. These modulators, one to each block, move the whole block bodily in frequency, each block being moved by 60 kc/s more than the preceding one. In this way, if there are n blocks, the whole spectrum from f_1 to $f_1 + 60n$ kc/s becomes filled with channels. The displaced blocks are collected

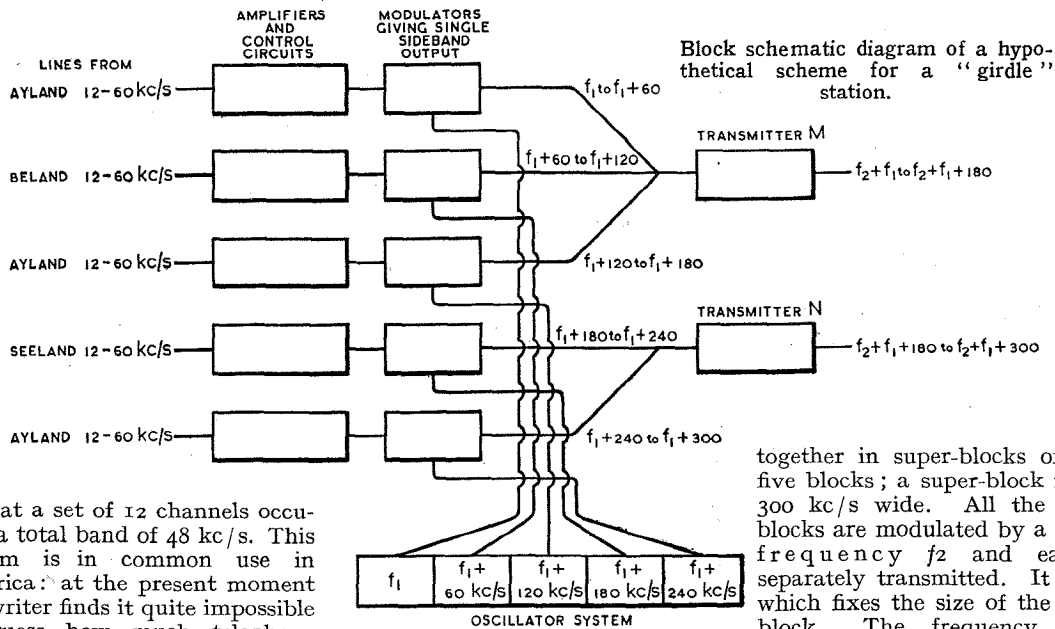

so that a set of 12 channels occupies a total band of 48 kc/s. This system is in common use in America: at the present moment the writer finds it quite impossible to guess how much telephone plant is still usable in liberated Europe. Let us assume that our continental communications are set up on a basis of 12-channel carrier systems. For simplification, assume also that any one channel may have substituted 30 sub-channels each of 100 c/s wide, to be used as telegraph channels handling 60 words per minute each. The problems of loading statistics will not be tackled here: clearly the transmission level of such telegraph channels must be fairly low.

Within Europe and America a tight mesh of these 12-channel systems must clearly exist: with these purely internal continental communications we are not concerned. Our girdle, however, is capable of accepting 125 blocks from the 12-channel system. Let us therefore allocate to each state or administration a number of

and so on. Each block has a code number, indicating its position in the 6-Mc/s band which constitutes the girdle, and any organisation having several blocks should have them spaced uniformly across the girdle band, so that the good and bad transmission regions are fairly shared. An organisation which is prepared to accept a poor service may be allowed to use the extremes of the girdle band at reduced prices to allow for the risk of penetration at the high end or high attenuation at the low end.

At the girdle stations we shall then have arriving an average of about 20 12-channel block cables (there can hardly be an enormous demand in Honolulu or San Juan). A simple and uneconomic plan is to transmit the whole lot, irrespective of whether or not there is any traffic actually being

together in super-blocks of, say, five blocks; a super-block is thus 300 kc/s wide. All the super-blocks are modulated by a second frequency f_2 and each is separately transmitted. It is this which fixes the size of the super-block. The frequency f_2 is selected by the girdle-control staff and is changed at intervals during the day in order that the whole of the girdle band may be adequately transmitted. It will be seen that only one frequency, f_2 , at any girdle station need be specified. The operation of the system should therefore be simple.

Certain channels will be permanently in use between two countries. Other channels will be wanted for general-purpose use—now to America, now to Australia. Each girdle station must therefore have enough demodulating equipment to break down a part of its traffic to audio frequencies, and then modulating equipment to set up the traffic from various sources into 12-channel blocks for passage to the lines or VHF links.

That is our sketch of the simple scheme. The detail planners will

Inter-continental Communications—have to consider an alternative, however. If we look at the traffic on this system we shall find that quite often in the slack periods several blocks have perhaps only one channel in use. If these could be brought together, it would be possible to reduce the number of super-blocks and thus the number of transmitters in use. We can thus draw up a scheme in which each block is broken down into its constituent audio-frequency channels; some are then recombined into 12-channel blocks, some into super-blocks and then transmitted. This would involve more apparatus, operators, traffic controllers, but would provide for lower actual equipment running costs, a better service and a service which can be built up bit by bit as the demand on its traffic-handling capacity grows.

In addition to the ordinary organisation of a communications system, the girdle project would merit a constant propagation prediction service, with ionospheric research stations arranged at intervals round the girdle, relaying their results to a central forecasting office. The mass of data thus accumulated should be of great importance for the scientific study of the ionosphere.

There is no claim here to have done more than describe how the writer would, were he responsible, approach the girdle-planning problem. Other schemes may be sounder economically; only the traffic experts can say. But it is clear that we must have something of this kind, and that the more it is tied up as an international system the less easy it will be for any State to contract out of the comity of nations.

work, well played, in the presence of what, to the pure scientist, is intolerable distortion. I would suggest, therefore, that the programme material is the one thing which a sound reproducer distorts very little, if at all. If this idea that the major artistic content is in the programme is accepted, I am led to believe that objections of imitation can be neglected, and that *artistic* satisfaction in the presentation of the sound itself is less important than Mr. Hartley would have us think. What is important, in my view, is that the distortions should not be such as to detract from one's concentration on, and hence full emotional enjoyment of, the programme.

Furthermore, I am not at all sure that I want to present sound in my own home artistically in the manner suggested. When I go to a concert or theatre, I go to relax, to listen and to enjoy someone else's artistic presentation. Why should I change my attitude at home? Fiddling with controls completely destroys all enjoyment of the programme for me, and if others are listening I always feel that my subtle adjustments pass unnoticed. I think one should make the best compromise for non-distracting sound, make up one's mind to accept it for what it is, and then sit back and listen.

I do not agree with the suggestion that high-fidelity reproduction will not give us the results we desire. I think it will, provided high fidelity is defined to cover all forms of distortion. But in practice high fidelity means wide frequency range, level response and low harmonic distortion, because these are the only distortions of the apparatus under the direct control of the designer. Over other distortions such as low signal-to-noise ratio, scale distortion, room resonances, reverberation and monaural sound he has no direct control.

It is only to be expected, therefore, that in the absence of complete control, some compromise has to be made. With records, frequency range and response has to be sacrificed to low signal-to-noise ratio, and here Mr. Hartley, with his sharp dip, has given us a new line of experiment. "Cathode Ray" has pretty well exhausted the subject of scale distortion, but on the acoustic side a tremendous amount yet remains to be done. I

Letters to the Editor

Synthetic and Reproduced Music • Improved Colour Code

"Aesthetics of Sound Reproduction"

I REALLY feel that Mr. Hartley has gone a little too far.

I have no quarrel with his suggestion of using dips in the response curve to cover up certain distortions—as a matter of fact, I am at present fitting such a circuit in pre-set form to my own gramophone—but that surely cannot mean that either of us should give up the attempt to evolve a system of reproduction needing no special treatment.

Mr. Hartley gives the analogy of the colour-print, and correctly calls it an imitation because it is executed in a different medium from the original. However, in the case of sound reproduction the medium is the same, and if a system is evolved which faithfully reproduces at the listener's ear the variations in air pressure impinging on the microphone, then the effect on the listener cannot be different from that produced if he were standing close to that microphone.

I do not suggest that such results are possible now, but

please let us keep trying. The ordeal of listening to a reproducing system in which the response is altered at intervals is by no means unfamiliar, and I cannot say I find it musically attractive.

Brighton. E. K. M. BIRD.

I FEEL that H. A. Hartley's recent essay should have been entitled "The Aesthetics of Music Reproduction," for it is clear that he is mainly concerned with the reproduction of music, and classical music from records at that.

While I do not deny the important place music has in sound reproduction, I think that the discussion of imitation, artistry, etc., has caused some misinterpretation of the general problems of sound reproduction.

It is my experience that intelligent people listen more to the programme material than to the precise quality of the sounds involved. People will understand and appreciate a good radio play whether they are listening on a midget or a radiogram. Similarly, musicians, I have found, will understand and appreciate a fine

regard the acoustic link as the weakest in the reproducing chain. Not only has a satisfactory method of getting deep, clear harmonic-free bass in the home yet to be devised (large amounts of negative feedback, whether by cathode follower or not, are a great help here) but ways of simulating binaural sound should be investigated. For example, a single loudspeaker for news bulletins, with two extra, widely spaced, speakers to give breadth of sound source for orchestral items. Checking of overall frequency response and measurement of reverberation also need to be done. Clearly a whole field of experimentation lies open to the enthusiast. A lot can be done with a home-made ribbon microphone, a beat frequency oscillator, a cathode-ray tube, and a pair of ears.

In short, my conclusions are much the same as Mr. Hartley's. "Doctoring" has to be done at the receiving end. I think more can be done than he suggests, but I have doubts about the importance of the artistic in the control. I see no objection to high-fidelity reproduction in its fullest sense. Acoustic and electrical improvements at the transmitting end (radio or record) are also needed.

The subject is a vast one, and, since it is largely closed to precise measurement, a very controversial one. I hope that many other readers will feel the urge to contribute their views. D. ROE.

Malvern, Worcs.

"Towards Synthetic Music"

I CANNOT view with other than feelings of the most excruciating horror the prospect unfolded by Patric Stevenson¹ who uses my articles² as a peg on which to hang his plea for synthetic music.

I accept his rebuke that my "discoveries" are somewhat late in the day, pausing only to point out that I have refrained from writing on this subject until I had discovered some practical way of handling the problem and then tested it out very thoroughly on an extremely mixed bag of "auditionees." I feel that it is important for a writer on such a subject to undertake extensive experi-

The Editor does not necessarily endorse the opinions of his correspondents

mental work before rushing into print, but that, clearly, is not Mr. Stevenson's method.

My main quarrel is with his concept of the future of music. There can be no argument that by constructing a complicated wave-form on, say, a transparent film, passing that film through a "sound head," and causing the resultant electrical energy to drive an amplifier and loudspeaker, a sound will be produced—but what sort of a sound? The perfection of tone in musical instruments has been brought about by research and experiment, and that perfection is assessed by æsthetic standards which must be agreed before you can begin to talk about creating "more perfect" tones. Each instrument, depending on how it is played and the pitch of the note that is played, has a characteristic wave-form. When a whole orchestra is playing, the wave-form at any instant is terribly complex; so complex, I venture to say, as to be incapable of analysis.

For the life of me I do not see how Mr. Stevenson's "synthetic composer," with the most delicate manipulation of millions of stencilled wave-forms, can hope to compete with an existing orchestra "reproduced" by a high-fidelity radiogram.

We can dispel the fantasies created by Mr. Stevenson's uncontrolled enthusiasm by considering a simple analogy. One can buy the music of a Beethoven Piano Sonata. That music indicates exactly the notes Beethoven wanted the pianist to play in a performance of his composition. A long strip of paper, wide enough to cover the tracker bar of a pianola, can now have slots cut in it exactly corresponding with the length and pitch of the notes of the sonata. If the roll of paper is now "put through" the pianola you will get a performance of the Beethoven Sonata. Why, then, do we bother to engage eminent pianists, demanding high fees to perform at concerts, when all we need do, apparently, is to hire a pianola and a roll of paper? Simply because the

pianola, like a steam organ at a fair, is mechanical and not artistic.

As compared with cutting a pianola roll, the task of Mr. Stevenson's synthetic composer is very much more difficult. If he wanted to imitate *just a pianola* he would first require 88 stencils merely to run up the keyboard at constant sound output. The 88 would have to be multiplied by, say, 10 to cover different intensities of each note. But this is only the beginning. Every time he wants to play two notes simultaneously, he must evaluate a new stencil, being a combination of the stencils of the two notes. The

number required will be $\frac{880!}{878! \times 2!}$.

The number required for three notes played simultaneously will be $\frac{880!}{877! \times 3!}$, and so on. Bearing

in mind that ten fingers may be called upon to play ten notes (we can forget the Chopin Polonaise in A which must have twelve notes played simultaneously) the total number of stencils required to cope with the repertoire of a pianist will be

$$\frac{20}{53} \left(\frac{880!}{878! \times 2!} + \frac{880!}{877! \times 3!} + \dots + \frac{880!}{870! \times 10!} \right)$$

(the factor $\frac{20}{53}$ representing the limitations of a pair of human hands). The sum of this series is 2.780306×10^{22} . Having thus equipped himself with this enormous collection, our synthetic composer is now able to imitate a pianola. How, in Heaven's name, would he imitate or surpass a Horowitz or a Schnabel? I think it will be clear that to "compose" music such as would be produced by 100 super-eminent instrumentalists presents rather grave difficulties. It would not, in fact, be difficult to prove that there is not enough matter in the universe to provide enough stencils.

On the other hand, I admit that no attempt need be made to imitate music as we know it, but to give us something quite different. I doubt if Mr. Stevenson has any more idea of what that "something" would be than I have, but it is a safe bet that it wouldn't be music. Considerable simplification of the complexities I have hinted at would probably produce the

¹ "Towards Synthetic Music"; *Wireless World*, September, 1944.

² "Aesthetics of Sound Reproduction"; *Wireless World*, July, August, 1944.

Letters to the Editor—

legato moo-ing which now characterises the sounds emitted by existing "electronic musical instruments."

I think, therefore, that until Mr. Stevenson withdraws his head from the clouds and gets down to something tangible and practical, readers of *Wireless World* are likely to derive greater satisfaction from experimenting on the homely lines I suggested in my own articles.

H. A. HARTLEY.

Isleworth.

Resistor Colour Code

THE suggestion made by C. R. Cosens in the September *Wireless World* for a change in the resistor colour code is sound as far as it goes. There is, however, the important fact that resistors marked according to his code would be indistinguishable from those using the present system, large numbers of which would necessarily still be in use. Any given combination of colours would, in general, have two possible meanings. Of course, a distinguishing mark might be added, but it would necessarily be small and easily overlooked, thus defeating the original object.

Some manufacturers now use three coloured bands at one end of the resistor, and since all three colours are then equally visible, no change such as that suggested by Mr. Cosens appears necessary. This system might well, therefore, be generally adopted.

D. JOHN BROCKINGTON.
Ilford, Essex.

THE remarks of C. R. Cosens in your September issue contain a suggestion which could add no real facility to the usage of colour-coded resistors. On the contrary, a reversal of the present "body-tip-dot" sequence would produce a state of affairs almost baffling description.

I have tried to point out the absolute necessity (which cannot lessen as time goes on) for *International* agreement in matters such as this. It almost certainly is too late to make such a change as a reversal of message. But present trends are tending to remove such difficulties as have been cited. Already, many manufacturers' machinery provides for a full-tip (instead of a half-tip)

and a cipher-indicating band (instead of a dot). I feel that this would lessen the need for gymnastics with a dentist's mirror.

May I be permitted to hint, however, as a guide to any further remarks on this subject, that we must expect that the future inevitably holds promise of more "bands." Already we need to indicate a finer Ω -tolerance than ± 20 per cent., where it is called for, and the future designer and user may need to be informed (who knows how soon?) on such characteristics as stability, and even inductivity, capacitance, voltage-coefficient, etc.

H. T. STOTT.

London, N.W.7.

Willans Oscillator Circuit

IN the *Wireless World* of Jan. 5th, 1939, there appeared an article by the late P. W. Willans entitled "Stages in the Development of R-C Controlled Oscillators." In that article the circuit of the Willans oscillator was given (see also Brit. Pat. 497148 of Dec., 1938). These facts ought to be brought to the attention of your readers in view of the independent, but slightly later, development of a similar circuit in the U.S.A.

References appear to be made

circuit of E. Lloyd Thomas (*Wireless World*, June, 1944) also appears to owe something to Willans.

The remarks above are prompted by my belated discovery of Willans' work, after I had wrongly attributed it to Americans.

In order to demonstrate oscillation without the use of inductance, a circuit was set up for AF, but particularly for low frequencies. It is usual to vary the frequency of a Willans oscillator by variable air condensers of 1,000 μF maximum. This leads to the use of enormous values of resistance, for frequencies below 100 c/s. I therefore put forward a circuit with low (preferably wire-wound) resistances, and high values of C_1, C_2 .

The simple oscillator built to the circuit of the accompanying diagram was found to have an unexpectedly good performance, and is now in use as a laboratory source. There is no AVC, but if a voltmeter is used as shown, this is no great drawback. So long as the meter reading does not exceed 20 volts, the wave-form is excellent. When $C_1 = C_2 = 6 \mu\text{F}$, the frequency is as low as 6 c/s, and when $C_1 = C_2 = .001 \mu\text{F}$ the frequency is 28 Kc/s. Preferably

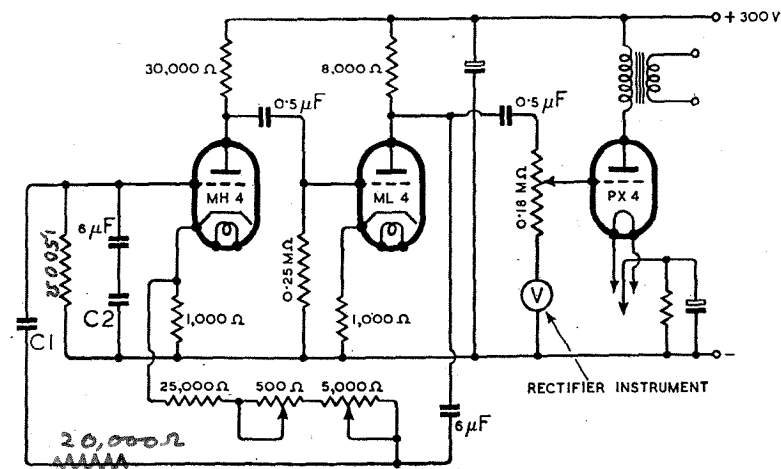

in this country more often to the American than to the British sources of this circuit. Thus S. K. Lewer, in *Wireless World* of Jan., 1944, develops a modified Willans oscillator, but refers to American sources in his bibliography (except for one British reference which hardly affects the argument). The Stable Negative Resistance Cir-

C_1 should equal C_2 roughly, but C_1 may be kept up to $10C_2$.

As a source for AC bridge measurements, and as a means of obtaining frequencies below 100 c/s, the Willans' oscillator seems to be outstandingly economical both in size and cost.

E. A. HANNEY.

Coventry Technical College.

RADIO HEATING IN INDUSTRY

Examples Illustrating the Versatility of this New Technique

THE principles of radio heating and the design of RF generators suitable for this work have been the subject of articles in recent issues of this journal, and it is thought that readers may be interested to learn of some of the uses to which this new technique is being put in widely diverse manufacturing processes.

The gears used in high-speed portable electric tools are called upon to sustain exceptionally high loads, and their life as well as their silence in operation are dependent on the accuracy of the form and pitch of the teeth. Small pinions on armature shafts having very few teeth and running at speeds up to 20,000 r.p.m. have normally to be carefully lapped after hardening to eliminate scale deposits and slight distortions if harsh running is to be avoided. Black and Decker, Ltd., Harmondsworth, have now installed high-frequency induction hardening equipment and report that it has enabled them to make a great stride forward in overcoming this problem. Not only is distortion reduced to a minimum, but there is a complete absence of scale on the tooth flank, and the quality of the gears manufactured in this way is generally of a higher standard than those made by earlier and more laborious methods. Formerly, components were heat-treated before machining, which increased their machining time. This has now been reduced by 40 per cent. since the steel can be machined in the fully annealed condition. Further, the hardening obtained with induction heating is confined to the surface, and the main body of the steel is left comparatively soft. Advantage has been taken of this selective hardening in dealing with splined shafts, which can be hardened at the wearing portions only, leaving other parts in the original soft state.

News of quite a different application of radio heating comes from Aero Research, Ltd., Cambridge, who are specialists in synthetic resin adhesives. It is well known that parts of wooden frame

aircraft involving curvature in more than one direction have to be built up by "tailored" veneers laid on a shaped moulding using special synthetic glues which "cure" comparatively slowly at shop temperatures. In laying up the veneers, difficulty is experienced in edge-gluing successive layers on the mould, and the standard practice of heating the glue line with a soldering iron and applying side pressure by hand is

the edges firmly holds the assembly in position so that it can be removed from the mould or jig and placed on one side for the main area of the glue to set.

The "gun" consists of a short length of tuned concentric line giving a concentrated electric field in the vicinity of the end of the centre rod. It is fed through a flexible transmission line from an oscillator delivering about 100 watts at 170 Mc/s. The gun is tuned by means of a sliding button and resonance is shown by the brightness of an indicator lamp. Power is automatically switched on when the gun is pressed against the work and an adjustable process timing circuit with a range up to 12 seconds switches off the power after the required interval. In the case of a glue line under a 2 mm. veneer this will be about 2 seconds.

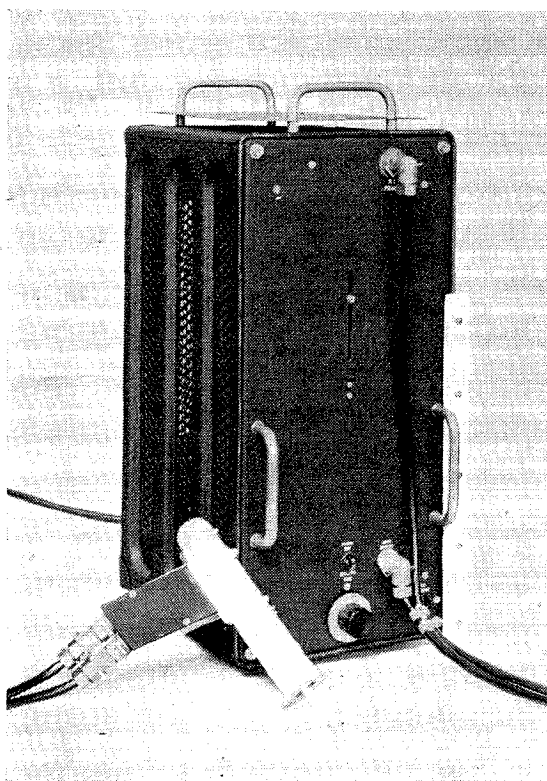

Portable RF "spot gluing" equipment developed by Pye Telecommunications, Ltd., for Aero Research, Ltd.

both slow and uncertain. The use of metal staples and paper tapes is also restricted to places where they can be removed before the work is finished.

These difficulties have been overcome by a "spot gluing" technique in which small areas of the order of $\frac{1}{4}$ in. diameter are heated by means of a radio-frequency "gun." The time taken to set the glue by this method is a matter of seconds, and a line of cured spots along

The equipment has been developed by Pye Telecommunications, Ltd., and is housed, together with its power supply unit, in a steel case with carrying handles measuring 18 in. x 10 in. x 8 in. and weighing only 45 lbs. It runs from AC mains, 190-240V, and consumes 600 watts. At the moment the apparatus is available only for high priority work, and requests for demonstrations should be made to Aero Research, Ltd., Duxford, Cambridge.

UNBIASED

Razor Radio

NOWADAYS we have to do without a great many of the lotus-eating sort of luxuries to which we were accustomed in the degenerate and soft-living times of peace. For many months past my trousers have owed their support to string and safety-pins, as Mrs. Free Grid has been far too preoccupied with the sterner affairs of war to carry out the necessary repairs.

Scotsmen are luckier in this respect than we effete southerners, although I must confess that I have never received a satisfactory answer to the question of how a kilt is supported, any more than I have to

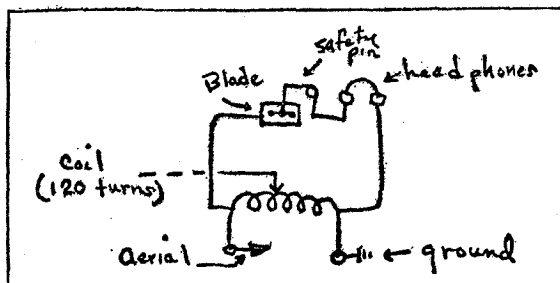

Courtesy: *New York Times*

The World's Simplest Receiver.

the equally burning question as to whether a true descendant of Bruce and Wallace wears anything under his kilt to keep out the chilling blasts of winter.

Radio, too, has known its shortages and its makeshifts, but even in the darkest days of the valve shortage we in England were never reduced to the degree of radio austerity experienced by the American troops on the Italian front. To them, even the humble crystal was an unobtainable luxury, reserved only for four-star generals and dictators of similar high degree. Apparently the humble private sitting in his Italian foxhole was compelled to forgo the luxury of a crystal and catswhisker and use in their stead a razor blade and a safety-pin, and I reproduce herewith the circuit of his set as published in the oversea edition of the *New York Times* which a correspondent has so kindly sent me.

Apparently American safety-pins, like American blondes, are rather different from our own home-grown variety, as they have a point at each end. The instructions in the newspaper state that one leg of the pin is jabbed into the baseboard, leaving the other leg free to be scraped along the flat of the blade, which

By

FREE GRID

should be nailed firmly down. Best results are obtained by pushing the point against the roughened part of the blade, where the maker's name is etched on to it. For sergeants and other plutocrats who own pencils, better results still can apparently be obtained by using a pencil as the catswhisker.

It goes without saying that results are excellent since neither you nor I have ever read a wireless constructional article in which this claim was not made, except, of course, in *Wireless World*.

There is, as far as I can see, only one fly in the ointment: where on earth is the razor blade to be obtained? It is, in fact, only this snag which prevents my giving you the result of my own experiences with this set. If any of you hoary old mechanised Victorians,

who still use the old-fashioned safety razor in place of a modern electric shaver, can supply me with a razor blade I shall be more than grateful. My complete spy's trans-receiver will then be perfected, as there are few better emergency spark transmitters than an electric razor with an aerial and earth connected across the contact breaker.

Radiomancy Vindicated

FEW people will dispute the fact that the European War is much nearer to its end now than it was in September, 1939, although when I ventured to put forward this opinion the other day at one of Mrs. Free Grid's War Savings bun-fights I was sternly denounced as a wishful thinker. The truth is, of course, that logic and simple statements of fact are foreign to the feminine mind. Wrap the truth up carefully in pseudo-scientific jargon and women will listen to you. I well recollect that an old and experienced medico of my acquaintance told me that in his early days he nearly went bankrupt through prescribing to his women patients simple and easily recognisable remedies such as bicar-

bonate of soda for the more vulgar afflictions of the body. It was not, in fact, until he sent a patient off to the chemist with a prescription for a bottle of H₂O that his reputation was made and from that day forward he never looked back in his professional career.

Like Mark Antony, I seem to have been diverted a little from my main object by women. What I wanted to talk to you about was radiomancy, or the foretelling of the future by radio, and to remind you that many months ago I gave in these columns the date of the end of the war (October 27th), carefully worked out by the new science; at the moment of writing it looks very much as though radiomancy is to be established as an exact science. I must not forget, however, that it was the Editor who put me on the track of this new branch of science when he permitted the publication in March, 1942, of the famous letter which was headed "What the Sunspots Foretell."

As a result of the publication of that letter and of my remarks on radiomancy and rhabdomancy and the remarkable connection between them I received a good many enquiries as to how they both worked. At the moment I am not in a position to discuss the matter, as the subject remains on the Government's secret list and Mr. Morrison



Foretelling the Future.

is still on the prowl seeking whom he may devour. The utmost that I can say at present is that according to a new theory on which I am working sunspots owe their origin to radio waves. It is true that sunspots existed long before Marconi was born, but so did radio waves, as all radio men tacitly admit by branding one particular kind of interference as *man-made*. More about this after V-day on October 27th.

Angles on **BRIMAR PRESTIGE**

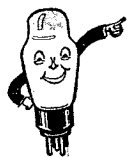
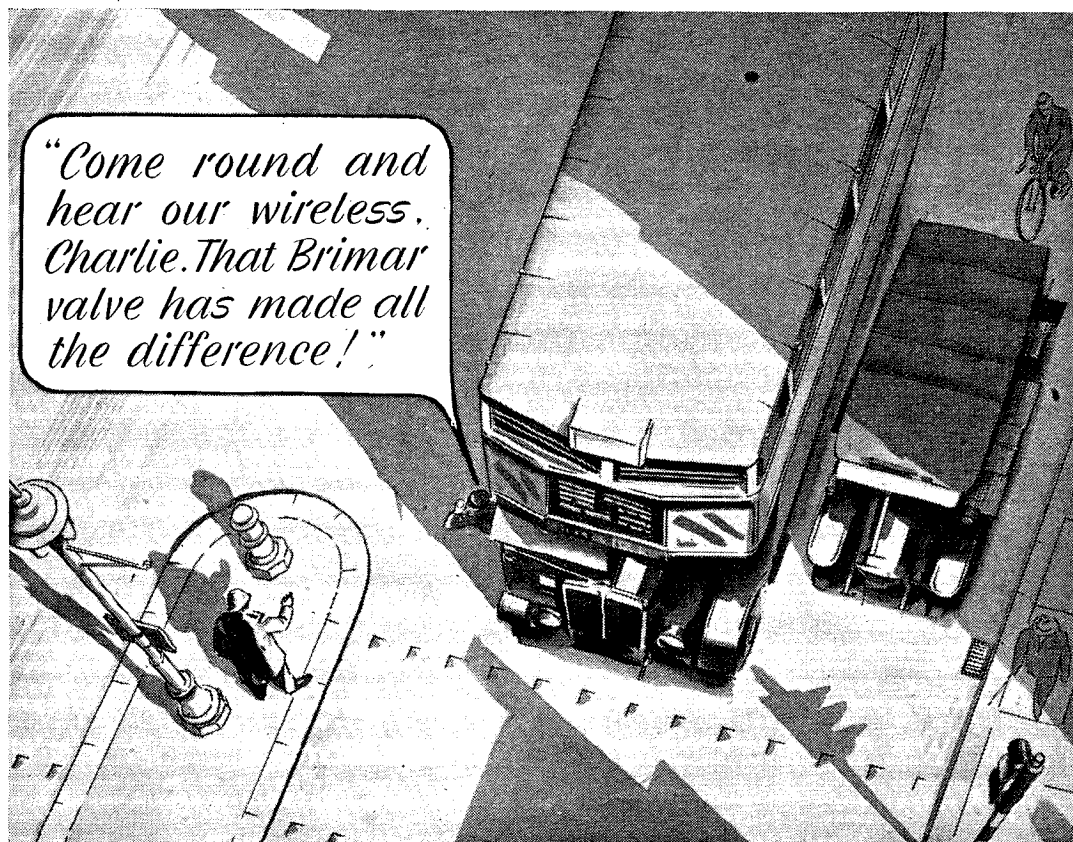

Engineers know that Brimar Valves operate within very close limits with unfailing reliability. That's why they often make "all the difference" to radio performance. Although still in short supply, you may be fortunate to get the Brimar Valve you need.

BRIMAR

BVA

VALVES

STANDARD TELEPHONES AND CABLES LIMITED, FOOTSCRAY, SIDCUP, KENT.

The right tool for each job

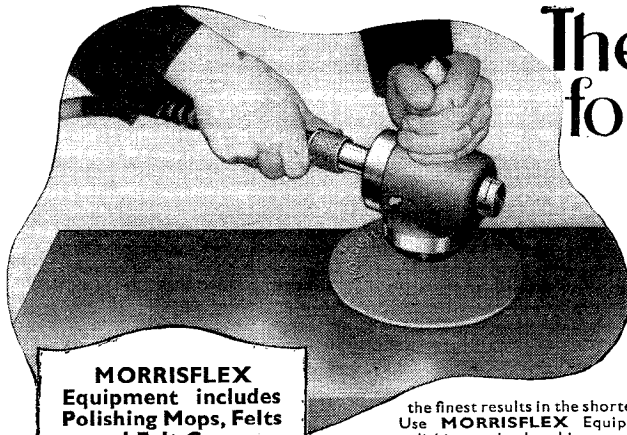

MORRISFLEX
Equipment includes
Polishing Mops, Felts
and Felt Cones.

Rotary Rasps
for Woodworking.
Mounted Points.

MORREX
Industrial Wire
Brushes.

REX
Rotary Files and
Cutters.

Sanders & Grinders,
etc.

the finest results in the shortest time and at minimum cost. Use **MORRISFLEX** Equipment for scaling, sanding, polishing, tube brushing, removing paint and rust; for rasping woodwork, and many other operations. **MORRISFLEX** Equipment is available in overhead suspension, bench and floor type machines, the two latter being readily portable.

Write for Catalogue

*On Air Ministry,
Admiralty and
War Office Lists*



Morrisflex FLEXIBLE SHAFT EQUIPMENT

Shirley 1237 B, O. MORRIS LTD., SHIRLEY, BIRMINGHAM, 'grams: Morrisflex, B'ham

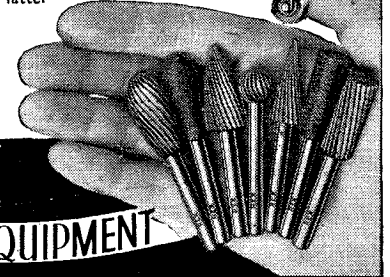
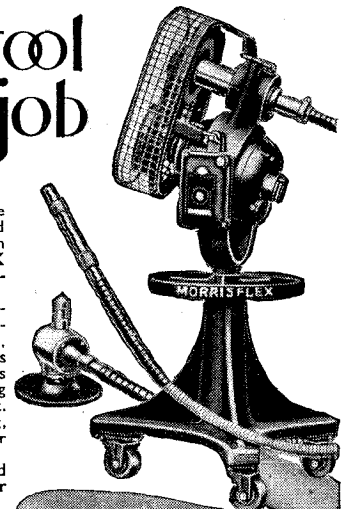

TOWERS OF STRENGTH

for use with
high voltages



The outstanding characteristics of U.I.C. Ceramic Pot Condensers are their high break-down strength, low loss factor, and small dimensions. *Test Voltage* up to 15 KV D.C. or 10 KV R.M.S. *Working Voltage* up to 7.5 KVD.C. or 5 KV R.M.S. *Radio Frequency Working Load* from 2.5 to 15 KVA according to type. *Capacity Range* 20pF to 1250pF. Made to Specification K.110. Full details on request.

UNITED INSULATOR CO. LTD.
12-22, LAYSTALL STREET, LONDON, E.C.1

Tel.: TERminus 7383 (5 lines) Grams.: Calanel, Smith, London

THE PIONEERS OF LOW LOSS CERAMICS

WAVE GUIDES

Modes in Circular Guides : Launching and Collecting Devices

IN building up our picture of the field pattern in a guide, a certain relationship between wavelength, λ , guide width, a , and "zig-zag" angle, θ , was accepted in blind faith. This assumption led to a pattern in which zero electric field occurred along the lines where back and

By
Sqd. Ldr. M. G. SCROGGIE
(Concluded from page 261 of the previous issue)
in Fig. 10. This is described as a different mode of wave propagation along the guide. It is more of theoretical than practical interest, however, because for a given

possible H modes is meant the number of "magnetic loops" across the dimension a is added; for example, H_1 for Fig. 8 and H_2 for Fig. 10.

There are also possible alternative field distributions along the dimension c ; for example, Fig. 11 (a) and (b) in which there are respectively 1 and 2 reversals of the electric field perpendicular to c . This is denoted by a

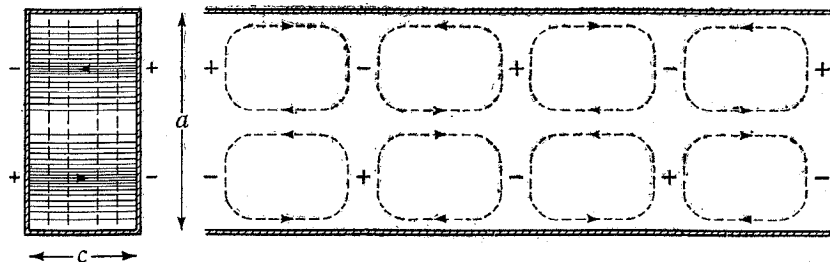

Fig. 10. When H_{02} waves are being propagated, the system is equivalent to two wave guides, each $a/2$ in height, stuck together and carrying H_{01} waves; compare this simplified H_{02} diagram with Fig. 8 (H_{01}).

front surfaces are joined by conductors. It thus satisfied an essential electrical condition. If it had worked out to give a resultant electric field across these short-circuits, then it would obviously have been a false assumption. Most other angles for a given ratio λ/a give such an impossible result, and are therefore incompatible with the propagation of waves along the guide.

The question arises now—Is this the *only* relationship that fits the conditions for propagation? Suppose the guide width is doubled, or the wavelength halved, the angle θ being kept the same. It is easy to see that this assumption also gives zero electric field along the boundaries of the guide, and in addition a line of zero field along the axis, where previously there was a maximum. The maxima now occur half way between the axis and the boundaries, giving a pattern as shown

wavelength a guide twice the size is needed.

It is easy to see that third, fourth, etc., harmonics of the original can also be propagated along a guide of this dimension a , using the same angle θ , but all other non-harmonic wavelengths involve different θ 's and therefore different phase and group velocities.

In all these situations, the electric field patterns are similar to those in the transmission line from which we started, in this respect, that they are *across*, and not *along* the guide. They are therefore sometimes called *transverse electric waves*, but more commonly they take the name of the field which has a component along the axis, in this case the magnetic. As H is the standard abbreviation for magnetic field strength, it is used to designate this type of wave propagation. To indicate which of the various

preceding subscript figure; thus the full designations for the types

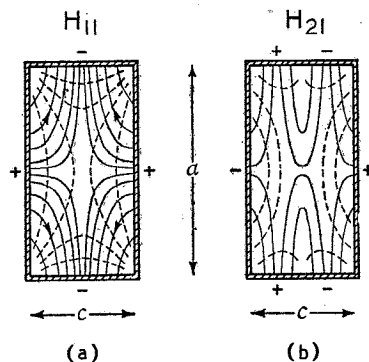

Fig. 11. More complicated wave modes show sinusoidal distribution of electric field along dimension c as well as a . In the H_{11} wave (a) there is one half sinusoid along each dimension; in the H_{21} (b) there is one along one dimension, a , and two along the other, c . The ends of the curved magnetic field loops are seen in these views.

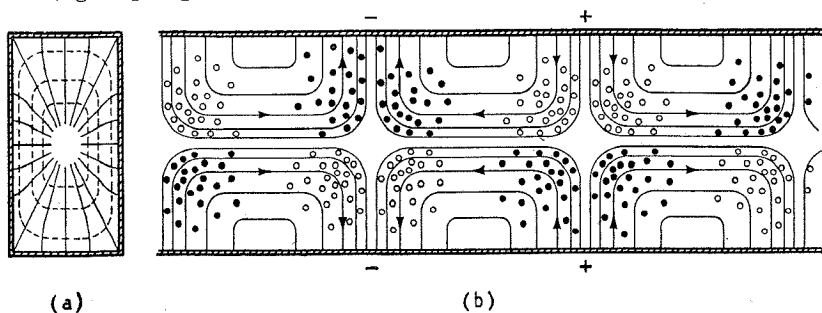

Fig. 12. End and side views of a guide with E_{11} waves. The magnetic loops are transverse instead of longitudinal as in the H waves, while the electric field is partly longitudinal. In the side view (b) the magnetic loops are shown in section, black dots indicating direction up from the paper and white circles direction into the paper.

Wave Guides—

of wave illustrated are: Fig. 8, H_{01} ; Fig. 10, H_{02} ; Fig. 11 (a), H_{11} ; Fig. 11(b), H_{21} . There is

of field loops encountered in moving through an angle θ of 180 deg., while the other (which, when omitted, is understood to

a radius. Fig. 15 shows the field patterns of E_0 , E_1 , H_0 and H_1 waves. In all these, of course, one has to imagine the patterns moving along the tube at phase velocity.

The E_0 system is interesting, because it may be regarded as a coaxial feeder in which the inner conductor is replaced by the axial capacitive path offered by the dielectric. Similarly E_1 waves can easily be recognised as analogous to those in a twin shielded cable.

The H_0 mode is unique, in that all the lines of force, both magnetic and electric, are completely "detached." As the metal tube itself, assuming it to be filled with dry air, having negligible dielectric loss, is the seat of losses, it is perhaps not surprising to find that in theory at least this mode is unique also in the

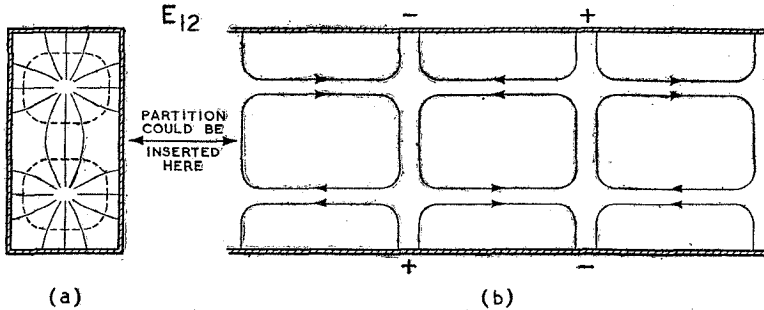

Fig. 13. As with the H_{02} system, E_{12} waves would be undisturbed by adding a longitudinal conducting partition, which would produce the equivalent of two adjacent guides with E_{11} waves (compare Fig. 12). For simplicity the magnetic loop sections are omitted from (b), and only single electric loops are shown.

no H_{00} mode. As H_{01} is the only type commonly used, we need not pursue the series further. The reason for its relative popularity is that for a given wavelength it permits the smallest size of tube to be used.

There is another series, distinguished by the feature that the axial component of field is electric only. They are therefore called E waves. The magnetic lines of force are loops parallel to a cross-section of the tube. The simplest mode is the E_{11} , in which the field patterns are somewhat as shown in Fig. 12. If the two sets of magnetic loops are contained in each cross-section, the mode is designated by E_{12} or E_{21} ; and so on (Fig. 13). E_{00} , E_{01} , and E_{10} cannot exist. The E waves in rectangular-section guides are not commonly used.

One is not bound to use a rectangular cross-section for wave guides. Another shape commonly used is circular. The nomenclature just described for rectangular guides cannot be applied to the circular type, in which

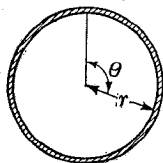

Fig. 14. Dimensions by which waves in cylindrical guides are specified.

dimensions a and c do not exist. The relevant dimensions are the radius r and the angle θ swept by a rotating radius (Fig. 14). Both H and E waves are possible, and one subscript denotes the number

be 1) indicates the number of loops encountered in moving along

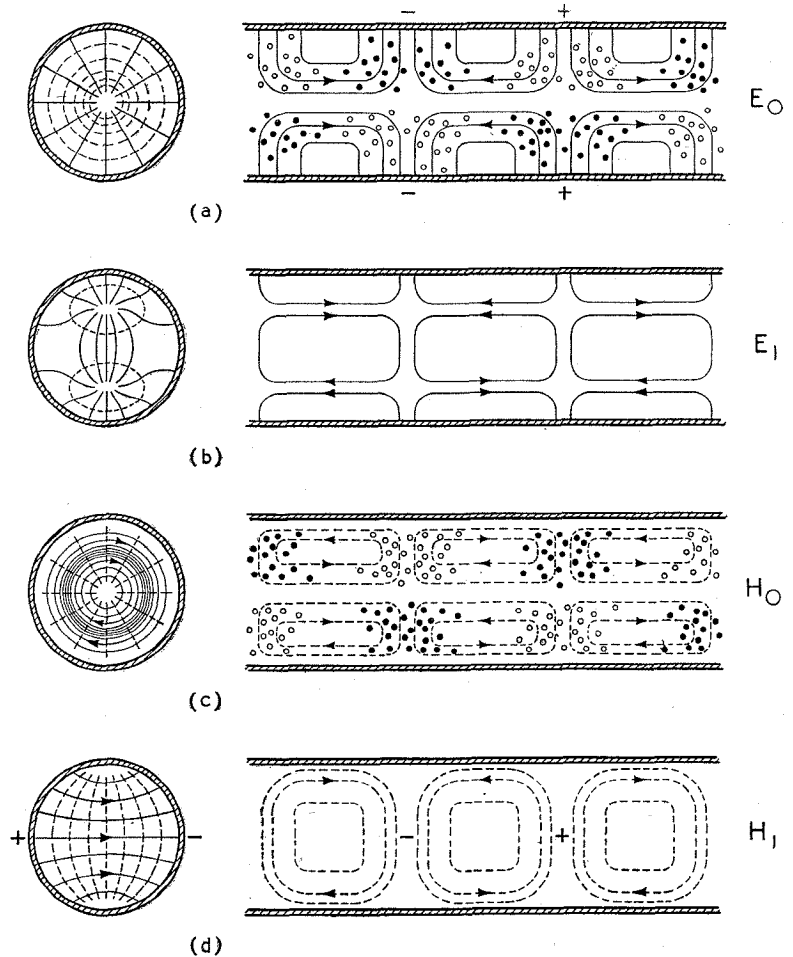

Fig. 15. Cross and longitudinal sections of cylindrical guides, with the modes of wave specified. In (b) and (d) the transverse field lines of force are omitted from the longitudinal sections.

attenuation continually decreasing as the frequency is increased. As Fig. 16 shows, all others have an optimum frequency at which attenuation is least; at higher frequencies it gradually increases,

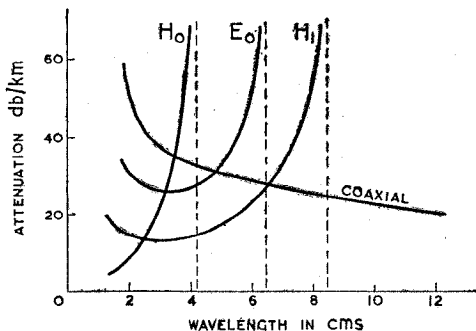

Fig. 16. Typical attenuation curves of three modes of waves in guides compared with that for cylindrical cable. The advantage of the guide is notable at wavelengths less than half critical. The critical wavelength is indicated by a vertical dotted line for each mode.

while at lower frequencies it increases rapidly, becoming infinitely great at the critical frequency (because then the wave cannot be propagated at all). In practice it appears that the curve for H_0 is similar to the others, because of inevitable slight departures from a perfectly uniform cross section.

The H_1 has the greatest critical wavelength of any in a circular guide, so, like the H_{01} in a rectangular guide, is the most economical of material for a given wavelength. The critical wavelengths in air for the most usual modes are:—

	Circular Guide	Rectangular Guide
H_1	3.41λ	H_{01} $2a$
E_0	2.61λ	
H_0 & E_1	1.64λ	H_{11} & E_{11} $\frac{2ac}{a^2 + c^2}$

An obvious necessity is some means of starting or "launching" the waves in a guide, and of picking them up at the far end. Fortunately these two problems are one, as the process is reversible. Nor, if its field pattern is considered, is it a difficult matter to derive means suitable for any type of wave that can be propagated. We have already noted that the E_0 pattern is similar to that in a coaxial cable, and in fact such waves can be set up by feeding them from a coaxial cable connected straight to it as shown in Fig. 17, with the inner conductor extending as a "probe" for about quarter of a wavelength into the guide. Similarly a twin feeder can be used to launch E_1 waves. E_1 waves can also be launched from a coaxial feeder as

shown in Fig. 18, in which the necessary phase reversal between the two probes is achieved by making the length l_2 half a wavelength greater than l_1 .

To launch an H_1 wave it is

necessary to set up an electric field across the guide, and magnetic loops along it. One way of doing this is by means of a transverse probe. To get the desired voltage maximum at each end of the business portion, it is necessary to extend it down a quarter-wave blind alley at the far end, as in Fig. 19. To obtain maximum excitation this distance

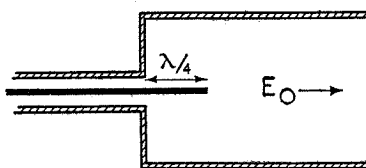
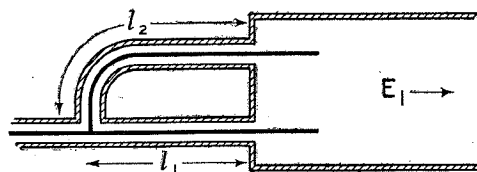

Fig. 17. One method of launching an E_0 wave into a cylindrical guide from a coaxial cable.

must be adjustable by a metal plunger P_1 ; and to obtain maximum propagation down the guide the waves reflected from its dead end are brought into phase by adjustment of another plunger P_2 .

The method shown in Fig. 19 also serves for launching an H_{01} wave down a rectangular guide if the existing conductor is

Fig. 18. Method of launching an E_1 wave from a coaxial cable. The opposite polarities in the two halves of the guide are obtained by making l_2 half a wavelength longer than l_1 .



at right angles to the larger cross-sectional dimension.

Alternatively a loop may be used, in a plane at right-angles

to the magnetic field in the type of wave desired. For example, by comparing Fig. 20 with Fig. 15(a) it can be seen that it would work as a launcher of E_0 waves.

There are circumstances in which it is advantageous to change from one mode of propagation to another. There are various ways of doing this, but perhaps the simplest is first to change the shape and direction of the guide so as to change the direction of the fields in the desired manner. For example, as the E_0 wave pattern is rather like that in a coaxial feeder and can be launched from such a feeder in the same axis (Fig. 17), and as an H_{01} wave can be launched from a coaxial feeder with the inner conductor at right-angles to the H guide axis, it is not surprising that H_{01} waves are started if E_0 waves are fed in at right angles as in Fig. 21. The process is reversible.

Whether wave transmission along a guide is initiated by a probe, aerial, loop or a "mode converter," it is unlikely that the desired mode will be completely "pure"; that is, un-mixed with energy in other modes. An advantage of employing the H_1 or H_{01} modes (in addition to that of economy of material used for constructing the guide) is the ease with which these unwanted modes can be filtered out, by making at least part of the guide length of such cross-sectional dimensions as to have a critical wavelength shorter than the wavelength to be transmitted, for any modes except H_1 or H_{01} . For example, suppose a 5000 Mc/s source of power is fed into a cylindrical wave guide in such a manner as to give rise to a proportion of E_0 waves as well as H_1 . The wavelength in metres is, of course, 300 million divided by the frequency in c/s. Or, more conveniently for these

"microwaves," wavelength in centimetres is 30,000 divided by frequency in Mc/s, so in this case it is 6 cms. As the critical wave

Wave Guides—

length for H_1 waves is 3.41λ or $1.7 \times$ diameter), and for E_0 waves is $1.3 \times$ diameter, the critical diameter for 6 cm. H_1 waves is 3.5 cms. and for 6 cm. E_0 waves is 4.6 cms. By using a guide with an internal diameter of, say, 4 cms. the E_0 waves (and,

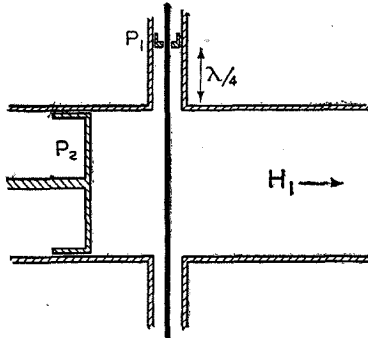

Fig. 19. The transverse electric field required for an H_1 wave may be generated by introducing the coaxial feeder at the side. The plunger P_1 is for obtaining the maxima in the right places, and P_2 is for reflecting waves in step with those already proceeding along the guide.

a fortiori, any higher modes) are attenuated practically to zero within a short distance of the starting point, while the H_1 waves continue alone. Incidentally, a tube smaller than critical diameter can be used as a calculable attenuator forming part of a standard signal generator. Other sorts of attenuator such as potentiometers, are of course quite impracticable at such high frequencies.

There are many devices—baffles, slots, discs, rings, etc.—that can be introduced into guides for the purpose of producing special effects such as inductance, capacitance, filtration, switching, etc., obtained in ordinary circuit practice by familiar components. Much will no doubt be heard and seen of this wave guide “plumbing” as the application of microwaves increase. Many of the devices are described in a paper of J. Kemp (*Journal I.E.E.* 1943, Part III, pp. 90–114.).

An important practical matter in the use of guides is the effect of joints, bends, deformations, etc. As one would expect from the analogy of transmission lines, sudden changes in dimensions cause reflections, and reduction

in power transmitted. They may also give rise to other modes of propagation. The ideal is a perfectly smooth inner conducting surface, uniform in cross-section and direction and without joints. In practice, it is necessary to take some care to keep the inner surface clean and dry. Joints are not a very serious problem; even the complete insulation of one section from another by a small gap produces less perturbation than might be expected; but of course a good internally-flush metallic joint is to be preferred. Ordinary mechanical tolerances in shape and internal dimensions are generally satisfactory. Gradual bends, in which the radius of curvature is large compared with the radius of the guide, have little effect; and sharp bends can easily be negotiated if they are suitably shaped. One such shape is shown in Fig. 22.

Arriving at the distant end of the guide, and still thinking of transmission lines, one naturally inquires about matching the load. As one would expect, a mismatch causes reflection of waves and consequent loss of power, but apart from trial (and that is not too easy) how can one tell whether a load will match or not? Has the guide a characteristic impedance, measured in ohms, to which the load must be equated?

The answer is that it has; but with this qualification, that it depends not only on the shape,

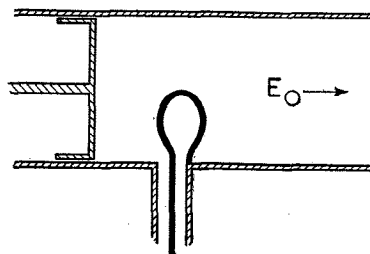

Fig. 20. E_0 waves can more conveniently be launched by a loop.

dimensions and material of the guide itself (as would a transmission line) but also on the type of wave. So although one can quite correctly talk about an 80-ohm coaxial line, one cannot do so for a wave guide without specifying the type of wave. A

guide that has a characteristic impedance of, say, 80 ohms for H_0 waves may be only 30 ohms for E_0 , while at a different frequency the impedance of the same guide may be greater for E_0 waves than for H_0 .

As with lines, the matching of the load may be adjusted by the coupling device. The equivalent of a matched ohmic resistor connected across a line for absorbing the whole of the energy, without reflection, is a resistive film across the guide. This may be convenient for experimental purposes; but the most usual purpose for which guides are used is to feed waves from some source to a place where they can be radiated (as the process of picking up radiated energy and feeding it to a receiver is merely the inverse use of the same equipment it may be taken to be included).

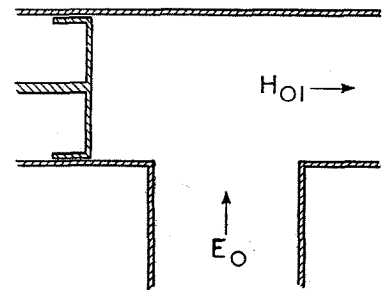

Fig. 21. If E_0 waves are fed into a guide at right angles, there is partial conversion to H_{01} or H_1 waves, depending on whether the second guide is rectangular or cylindrical.

In such a case the load is the radiator. It is possible to use one or more half-wave dipoles as a radiator. There is then the necessity for some sort of coupling device, and as it will almost certainly be desired to exploit the comparative ease with which very short waves can be “beamed,” either an aerial array is called for, with a feeder system that has to be correctly matched and phased—a process that is not so easy with centimetre waves as with metre waves—or a single dipole with parabolic reflector.

The acoustical analogy of a wave guide—a speaking tube—suggests that by flaring it out into a horn of the correct dimensions an efficient directional radiator may result. It does. An

electromagnetic horn may be used as a complete directional radiating termination of a wave guide, or may be combined with a reflector. It may be news to some readers that free space has an impedance

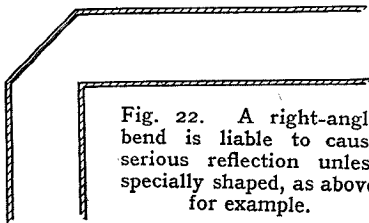

Fig. 22. A right-angle bend is liable to cause serious reflection unless specially shaped, as above for example.

that can be specified in ohms. That being so, for maximum efficiency as a radiator the flare at the end of the guide must be so shaped that it provides a match between impedance of space and that of the wave guide. It thus acts as a transformer. Although the problem of designing a horn for maximum efficiency and the desired directivity is beyond simple mathematics, the analogy between it and a loudspeaker horn on the one hand, and an aerial and aerial coupling transformer on the other, should provide a helpful picture of its action.

RANDOM RADIATIONS

By "DIALLIST"

The Transients of War

MUCH as I admire the B.B.C.'s daily "War Reports" I do wish they'd tell both their correspondents and those who edit their despatches for broadcasting not to try to record or to transmit the loud and angry sounds of war. "Listeners," we are told, "will now hear a recording of the most terrific artillery barrage in the history of warfare." What comes from the loudspeaker is reminiscent of a shooting gallery at a fair! The passing of mighty tanks sounds something like a kitchen mincing machine at work and the tramp of marching troops is not impressive. You can't do much with transients when you've but a narrow band of audio frequencies to play with, and the report of any piece of artillery involves the quintessence of transients. Some years before the war the Bell Telephone Company of America conducted a series of experiments to discover what was the minimum range of audio frequencies needed to make the electro-mechanical reproduction of such transients as drum beats, handclap-

To discover what modes are present in a wave guide, and to enable optimum adjustments of the system to be judged, one may explore the interior with a suitable pick-up and detector device. Assuming the guide is excited with at least a watt or so of power, the simplest detector is a small pea lamp, preferably with a straight-through filament, connected at the centre of a tiny dipole. The lamp glows most brightly when the dipole coincides with the direction of the electric field. Therefore if there is any glow when the dipole is parallel to the axis of the guide there must be some E wave present. Moving the detector axially along the guide will probably cause the brightness to wax and wane at intervals, due to standing waves. The termination of the guide should be adjusted until the glow is as nearly constant as possible.

The magnetic field can be mapped out by using a small loop instead of a dipole. If a response is shown when the plane of the loop is at right angles to the axis of the guide, there must be a longitudinal magnetic field, and hence an H wave.

ping and footsteps on a board floor sound natural. In theory perfect reproduction demands circuits with a faithful response to the whole gamut of audio frequencies. The practical experiments proved that a critical audience (which did not know when or where cut-offs were being brought into action) instantly detected something unreal in the reproduction unless practically the whole of the audio frequencies to which the ear of the average man or woman over about 30 years of age responds were there. I have not the figures by me at the moment, but, speaking from memory, I believe that the reproduction of handclapping was criticised if the upper cut-off was imposed below 16,000 cycles a second. If clapping demands a frequency response of this width, what about gunfire?

How Did Good Sets Fare?

Admittedly, I had perforce to hear these "War Reports" from the very ordinary loudspeaker of a very ordinary receiver. I should like very much to know whether

those fortunate enough to be able to handle in wartime receivers specially designed for the highest obtainable fidelity from not-very-high-fidelity transmissions found anything like reality in the reproduction by their sets of sounds of the kind I've mentioned. Doubtless their results would be better; but I find it difficult to believe that their loudspeakers gave them anything but a travesty of such sounds as those of gunfire heard at close range.

□ □ □

Jelly Acid Cells

MANY thanks to those kind readers who have responded to my recent request for hints on the best way of keeping jelly-acid accumulators up to the mark. I'd never had anything to do with cells of this sort till recently, having always used the kind with liquid electrolyte. I gather from what my correspondents tell me that I had been doing pretty well all the right things by the light of nature. The great thing is to prevent the jelly from drying up unduly and cracking. To this end cells should always be topped up before they are put on charge, any surplus liquid being poured off when the charge is complete. Also, it appears to be even more important than with liquid-electrolyte cells not to let them run down too far before charging. The only point wherein I differ from those who have sent hints is that they are unanimous in prescribing distilled water for the topping up, whilst I maintain that water from the tap is all that is needed.

Distilled or Undistilled?

Some time ago I mentioned that for years I had used tap water for topping up cells and that I'd never found any ill effects so long as it wasn't too hard. If tap water is on the hard side it should be boiled and allowed to stand for some time, not just to cool it, but also to allow the sediment to settle. The water delivered by the mains in my district is actually the hardest I've ever known. It furs up kettles and hot-water pipes with horrid rapidity—one hopes it doesn't have equally devastating effects on one's inside. But whatever it may do to hot-water systems it seems to be perfectly harmless to secondary cells once it has been boiled; certainly I've never had any complaints to make about car batteries or wireless batteries treated in this way. On the contrary, their service lives (and some of my wireless batteries have had pretty hard work to do) appear to be at least up to normal figures. I believe that tap water is used by

the G.P.O. for its accumulators, and lately the Army has relaxed its previous rigid rule about the use of distilled water.

□ □ □

Sound-wave Vagaries

IT'S surprising at what enormous distances you can sometimes hear explosions; surprising, again, that you may hear little or nothing of an explosion that takes place comparatively near to you. On one occasion in the last war when I had an A.A. battery on the outer defences of London I was rung up by a Very Important Person, who asked if I could hear gunfire. It was in the small hours of a calm, cloudy night. "Very clearly," I replied, "there's a continuous rumble and you can hear the individual reports of the bigger guns." "Where do you think it is?" enquired the V.I.P. "In France, Sir." It was the telephone that exploded then. I was an impertinent young whippersnapper, I gathered, who would decidedly not find that it paid to be funny with V.I.P.s. It took me all my time to convince him that I was not pulling his leg! Just the other day I was walking with another soldier in the country. Suddenly we stopped our conversation and listened. There it was again. "Heavy guns somewhere," he said, and I agreed. Again and again at intervals we heard the sound unmistakable to gunners. That evening we heard in the news bulletin that the big guns of Calais, 120 miles away, had been in action, probably using up their stores of ammunition whilst the going was still good. And here's a contrast. A "doodle bug" passed right over my head and cut out just as it was disappearing over a ridge some two miles away. I waited for the bang, but heard nothing. A dud, I thought. But it wasn't: it had topped the first ridge and a second smaller one and had exploded (quite harmlessly) in the valley beyond, about three miles from me.

Reflections of Skip Areas

A very loud noise appears to produce a "sky wave," which may in certain circumstances behave very much like its wireless counterpart. If the sky is overcast, as it was in both the instances of long-distance hearing that I've mentioned, the clouds may play the part of a kind of Heaviside layer, reflecting the sound waves back to earth. In such conditions explosions may be heard at great distances. But there may also be a skip area, just like that round a wireless transmitting station, where neither the direct nor the reflected wave arrives. The huge Silvertown explosion of the last war was audible at great

Wireless World

distances, but I heard no sound of it, though I was comparatively near at the time. In the case of the "doodle bug" I fancy that the intervening ridges blanketed the sound waves, probably reflecting them so that they passed high over the heads of people who were where I was.

□ □ □

Wave Guides

AS one who has had some dealings with the art of pouring wireless waves down pipes (that was the way that the student put it!), I congratulate Squadron Leader Scroggie on his lucid exposition of the workings of wave guides. I trust that you read and inwardly digested the first part, which appeared in the last issue of *W.W.* and will do likewise with what follows. His is the best simplified explanation that I've seen. We shall all have to know something about wave guides if we want to keep up to date with wireless after the war, for the microwaves are likely to have a good many important jobs assigned to them. Very queer and very interesting things they are, and it's surprising to find how easy to handle the apparatus that deals with them can be. Do you remember the awful struggles we had not so many years ago with receivers designed to cope with what we then regarded as the shortest of short radio waves? Despite long extension handles fitted to all the tuning controls and extensive use of screening, "body capacity" used to be such a bugbear that to pick up and hold a 30-metre transmission was once a feat demanding skill. The slightest movement might mean the loss of the signal. Things have changed a bit since then, and the microwave of to-day has been more successfully tamed than was the not-so-short wave in the nineteen-twenties and even the early nineteen-thirties.

□ □ □

Easier Servicing

IN *The Wireless Trader* a very interesting correspondence has been running on the difficulties that the serviceman encounters when he endeavours to adjust or repair many kinds of domestic receiver. Few designers have ever considered the unfortunate serviceman when making their layouts. And so it comes about that many minor jobs inside the set often can't be done without dismantling it to an extent that should be wholly unnecessary. During the war I have often responded to an S O S from friends who couldn't get their sets put right because their local serviceman was so chockablock with work. No doubt you've done the same. If you have you will know just how

exasperating many jobs can be; every component that you want to get at seems to be either behind or underneath something else! Sometimes you can't take the chassis out of the cabinet without unsoldering connections because the loud-speaker leads aren't long enough. Or you may find that odd components are mounted not on the chassis, but here and there on the inside of the cabinet.

Needless Complication

One of the worst crimes of all is the highly complicated circuit which has no justification whatever for its existence. After studying a circuit diagram (supposing that you're fortunate enough to find one available) you fiddle with the thing for hours without being able to get it to work satisfactorily. At length in exasperation you resolve to scrap the complications and to rewire so that the circuit becomes a perfectly straightforward and ordinary one. You get the set into operation and the owner tells you that it is performing as well as ever it did. Unless an out-of-the-way circuit really does something—and many of those that I've had to deal with in domestic receivers don't—it is ridiculous for a designer to incorporate it. There are dozens of ways in which receivers could be made simpler to service and I do hope that in the future our manufacturers will see that this is done.

□ □ □

Welcome Back

AS the Allied Armies advanced through France and Belgium it was good to hear stations in these countries returning to normal and no longer churning out the made-in-Germany programmes previously imposed on them by the unspeakable Hun. Cherbourg and Rennes were two of the first I picked up. Then came Paris and other stations. Some of the transmissions are still not strongly received at the moment of writing, but I expect that many of them will be back to their old form by the time that this is in print. Probably Kootwijk will have ceased to transmit the sorry performances of Lord Haw-Haw and his gang. The Boche has had a long innings in some of the best stations in Europe, but that can't last much longer now and soon we may hope he will be cleared out of them.

Valve Construction

OUR cover illustration shows the elements of an Osram valve during manufacture as seen by the operator through a magnifier when illuminated by fluorescent tube lighting. Reflections from the highly polished surfaces are eliminated.

CLASS "C" AMPLIFIERS

Reasons for Their High Efficiency in RF Circuits

THE subject of the Class "C" amplifier is one that has received rather scant treatment in many textbooks. Some writers are content to refer to "the well-known efficiency of the Class 'C' valve," and to leave it at that. Others do not go beyond giving as the reasons for the aforesaid efficiency the facts that the valve so employed is quiescent, save towards the peaks of the positive halves of the volt-

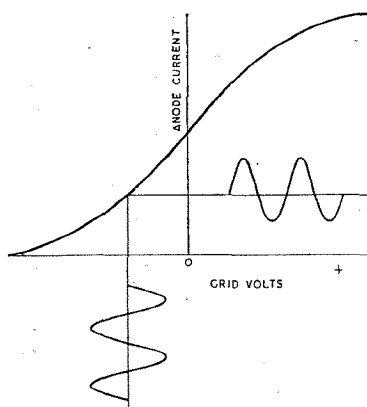

Fig. 1. Grid-volts/anode-current characteristics with Class "A" operation.

age cycles reaching its grid; that the whole of the grid-volts/anode-current characteristic is used; and that a valve in Class "C" can handle much larger voltage swings than one worked in Class "A" or Class "B." Those, in fact, are probably the only reasons that the majority of radio enthusiasts can call to mind if asked why the Class "C" valve is so efficient as an amplifier. The purpose of this article is to show as simply as may be that this is only half the story and that there are other and very important reasons for the wonderful performances of a valve working in Class "C."

The Class "A" valve is a voltage amplifier *par excellence*. Correctly used, it can pass on to the grid of a following valve voltage swings which are amplified and undistorted copies of those reaching its own. As a power amplifier it can be made to give an un-

By R. W. HALLOWS,
M.A., A.M.I.E.E.

distorted output, especially when working in push-pull; but, as users of battery receivers with Class "A" output know by sad experience, it is only at the cost of quite considerable input from the high-tension battery that it can enable the loudspeaker to deliver a reasonable volume of undistorted sound.

A glance at the familiar curves of Fig. 1 shows why this is so. Only that part of the anode-current curve which lies on the negative side of the zero line can be used. Nor is the whole of this portion available, for distortion is introduced if the valve is driven either up into grid current (which normally starts to flow some time before the grid is actually positive) or down to the bottom bend. Hence, if anything like a big grid voltage swing is to be handled without distortion, the straight part of the curve to the left of the zero line must be made long, and this can be done only by applying to the anode a considerable HT voltage, with a corresponding current drain on the battery.

There is a useful criterion by which the performance of a power amplifier in relation

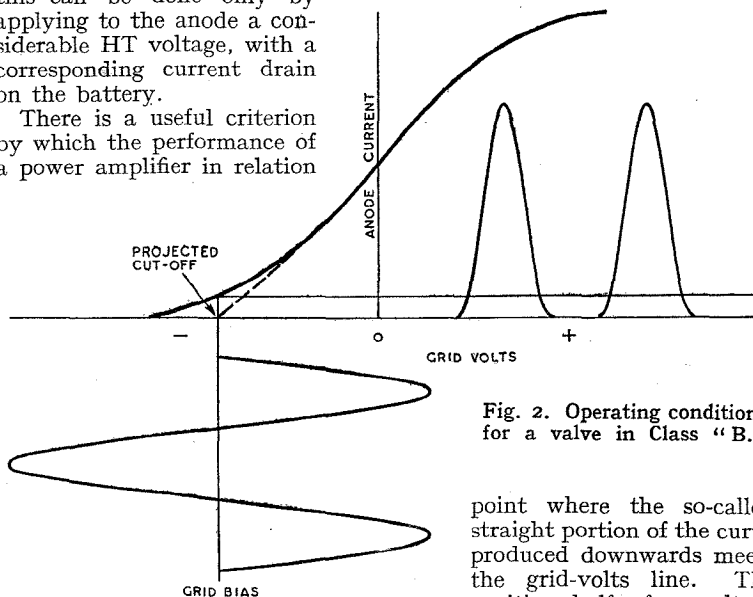

Fig. 2. Operating conditions for a valve in Class "B."

to operating costs can be judged. This is known as the *anode efficiency*. The anode efficiency is the ratio of RF or AF output watts to

the DC watts input to the anode. In a Class "A" amplifier an anode efficiency of 35 per cent. is about the most that can be hoped for, and 25 per cent. is probably a good working figure. Apply 1 watt of HT to the anode of a battery receiver's Class "A" output valve (10 mA at 100 V) and about a quarter of a watt of undistorted output may be expected to be delivered to the loudspeaker.

When Class "B" amplification made its appearance, a good many years ago now, it was hailed as the greatest boon so far vouchsafed to the user of a battery receiver. The dull-emitting filament had reduced the costs of low-tension supply; now Class "B" would cut down the even greater costs of HT. And it would do more: it would enable the man with the battery set to obtain good volume without unacceptable distortion.

The operation of Class "B" is seen in Fig. 2. A valve used in true Class "B" is biased to the "projected cut-off": that is, the

point where the so-called straight portion of the curve produced downwards meets the grid-volts line. The positive half of a voltage cycle reaching the grid brings a large portion of the characteristic curve into use: no anode current flows when a negative swing takes

Class "C" Amplifiers—

the grid voltage down below cut-off. Grid current flows during a large part of the positive half-cycle, and this must be made good by a driver stage preceding the Class "B" stage. The chief application of Class "B" is to the output stage of battery receivers. A

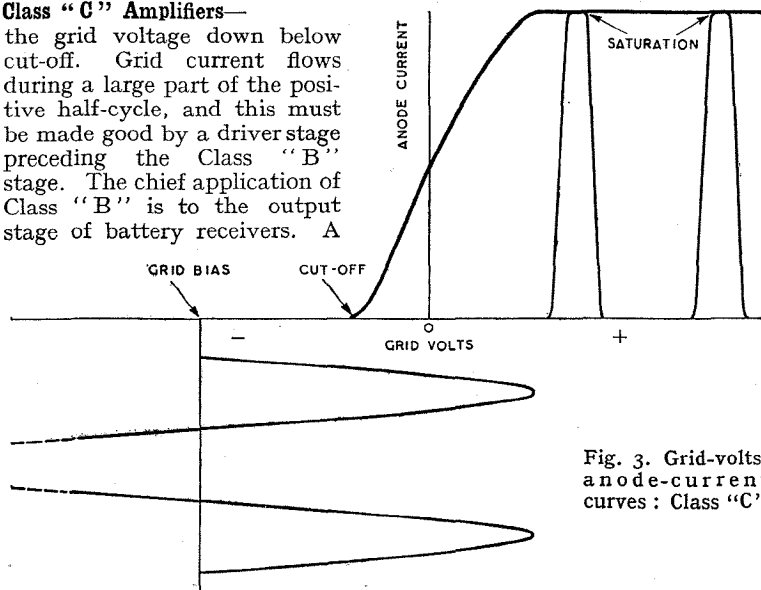

Fig. 3. Grid-volts/anode-current curves: Class "C"

single valve used in this way would give rise to appalling distortion, but with two in push-pull good reproduction is obtainable. The anode current adjusts itself to the incoming signal. With no incoming signal it is minute; with a strong signal it may be consider-

a preceding driver stage. Those which do so on large grid voltage swings are known as Class "AB₂."

In the Class "C" amplifier the negative grid bias applied is at least twice the cut-off voltage. Hence, as shown in Fig. 3, the

half-cycle has carried the grid voltage above the cut-off point. The whole of the grid-volts/anode-current curve is used: the valve starts to emit as the cut-off is reached, is driven right up to saturation and does not cease to emit until the voltage has fallen to cut-off. Grid current flows during a large part of the emission period and reaches a high figure when the peak of a positive half-cycle is on the grid; an ample driving stage is therefore required to precede the Class "C" amplifier.

The anode efficiency of the Class "C" amplifier is commonly 60 per cent. to 70 per cent., and an efficiency as high as 80 per cent. may be achieved with it. Clearly it cannot be used in receiving sets, for distortion would result even in push-pull circuits; but for transmitters it is the best of RF power amplifiers where high efficiency is required.

So far we have seen that the Class "C" amplifier surpasses Class "A" and Class "B" in the grid voltage swings that it can handle, in its use of the whole of the grid-volts/anode-current char-

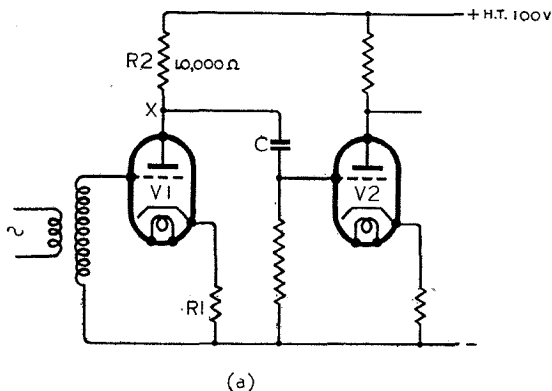

(a)

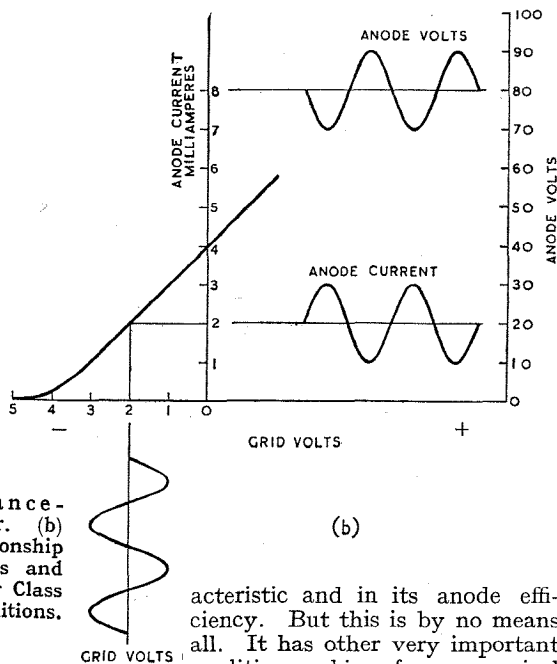

(b)

Fig. 4. (a) Resistance-coupled amplifier. (b) Showing the relationship between anode volts and anode current under Class "A" working conditions.

able. The anode efficiency of a well-designed Class "B" stage is much greater than Class "A" and may be 50 to 60 per cent.

It may be mentioned that between Class "A" and Class "B" proper two intermediate forms are recognised. Their family name is Class "AB" and their chief characteristic that the standing negative grid bias is greater than it would be in a Class "A" amplifier, though not so great as in true Class "B." Such an amplifier operates in Class "A" on a small grid swing and in Class "B" on larger swings. Class "AB₁" amplifiers do not draw current from

valve is completely closed down, not only during the negative half-cycle of an incoming grid voltage swing, but also during a portion of the positive half-cycle: the valve does not "open," passing anode current, until the positive

characteristic and in its anode efficiency. But this is by no means all. It has other very important qualities making for economical working.

Before we go on to discuss these it may be as well to spend a few moments in seeing what happens to the anode voltage of a valve when variations in the voltage applied to its grid are producing

variations in its anode current. This, by the way, is a point with which very few elementary manuals and textbooks of wireless deal at all adequately. I know from much experience that it is a stumbling block to many beginners; if, therefore, the reader is explaining the working of valve amplifier to a new hand at the game, he should be careful not to neglect it. What, in a word, the beginner cannot follow is this: he finds diagrams and letterpress showing how *voltage* swings on the grid are responsible for *current* swings in the anode circuit, which, he is assured, are (I quote one of the little books referred to) "faithful, but amplified, copies of the voltage changes reaching the grid." The diagram illustrating this statement is similar to that seen in Fig. 1.

The difficulty that presents itself to him is this. If there are two amplifying valves in cascade, we want to feed to the grid of the second voltage-swings from the output of the first. "But," says he, "my book deals only with current-swings in the anode circuit of amplifier.

Fig. 4 (a) shows two resistance-coupled amplifiers working, we will take it, in Class "A." The resistance R_1 gives the grid of V_1 a standing bias making it 2 volts negative with respect to the cathode. R_2 in the anode circuit has a value of 10,000 ohms. We will suppose that the voltage reaching the grid of V_1 is swinging from 1 volt positive to 1 volt negative. Fig. 4 (b) shows voltage and current curves for V_1 . When the incoming grid voltage is zero the anode current is 2 milliamperes. By Ohm's law $V=IR$, where I is the current in amperes. The voltage drop across R_2 is thus $10,000 \times 0.002$, or 20 volts. Out of 100 available HT volts 20 are dropped across the resistance, so that the anode voltage at this instant is $100-20$, or 80, as shown in Fig. 4 (b). At the positive peak of the incoming grid-swing the anode current is 3 milliamperes and the drop across R_2 rises to $0.003 \times 1,000$, or 30 volts. The anode voltage thus falls to 70 volts. It rises to 90 volts when the "trough" of the incoming grid swing brings the anode current down to 1 milliamperes, and reduces the volts dropped across R_2 to 10.

An incoming grid voltage-swing between +1 volt and -1 volt causes the potential at the point X in Fig. 4 (b) to vary from 70 volts to 90 volts—in this instance a tenfold voltage magnification—and the amplified voltage-swings are passed on *via* the condenser C to the grid of V_2 .

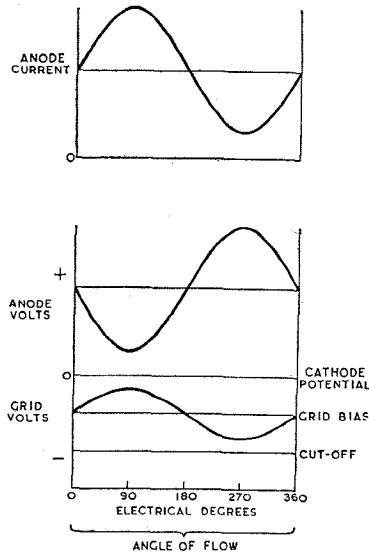

Fig. 5. The voltages through the valve and angle of flow in a Class "A" amplifier.

It is important to notice that a peak of incoming grid voltage produces a trough of anode voltage and *vice versa*. The voltage swings in the anode circuit are 180 degrees out of phase with those in the grid circuit and 180 degrees out of phase with the current swings. In other words, anode current, or emission from cathode to anode, is at its greatest at the moment when anode potential is at its lowest. Note that if a negative grid voltage-swing is sufficient to close the valve down, so that there is no emission from cathode to anode, there is no voltage drop across the load resistance in the anode circuit. The anode volts therefore rise to the maximum available and remain there until a positive voltage-swing on the grid opens the valve again.

Fig. 5 shows how a Class "A" valve deals with one voltage cycle on its grid. It will be seen first that emission from the cathode takes place during the whole 360 electrical degrees of the cycle. The angle during which emission takes place is called the Angle of Flow;

(Continued on page 312.)

GALPINS

ELECTRICAL STORES

"FAIRVIEW,"
LONDON ROAD, WROTHAM,
KENT.

TERMS: Cash with order. No C.O.D.
All prices include carriage or postage.

MASSIVE GUNMETAL WINCH, complete with long handle, for use with $\frac{3}{16}$ in. dia. wire cable, weight 50 lbs., condition as new. **£3.**

ELECTRIC LIGHT CHECK METERS, first-class condition, electrically guaranteed, for A.C. mains, 200/250 volts 50 cy. 1 phase 5 amp. load, **11/-** each.

SOLID BRASS LAMPS (wing type), one-hole mounting, fitted double contact, S.B.C. holder, and 12 volt 16 watt bulb. **4/-**.

TUNGSTEN CONTACTS, $\frac{3}{16}$ in. dia., a pair mounted on spring blades, also two high quality pure silver contacts, $\frac{3}{16}$ in. dia., also on spring blades, fit for heavy duty, new and unused. There is enough base to remove for other work. Set of four contacts, **4/-**.

RESISTANCE UNITS, fireproof, size 10 x 1 in. wound chrome nickel wire, resistance 2 ohms to carry 10 amps. **2s. 6d.** each.

3-PHASE TRANSFORMERS, 410v. to 240v. at 2kW, size of core 14 in. by 11 in. by 5 square inch section. **£10.**

AIR PRESSURE GAUGE by famous maker, 10 in. dia., reading 0-4,000 lb. per square inch, as new, in case. **£7 10s.**

SWITCH FUSE in wrought iron case, 3-way, for 400 volts at 40 amp. **45/-**.

MOVING COIL ammeter reading 0-350 amps., 6 in. dia., switch board type. Price **£3 10s.**

ROTARY CONVERTER, input 40 volts D.C., output 75v., 75 m/A, A.C., also would make good 50v. motor or would generate. **£2.**

DYNAMO, output, 20v.-10 amp. Ball bearing, shunt wound, speed 1,750 r.p.m. **£5.**

AUTO TRANSFORMERS. Step up or down, tapped 0-110-200-220-240; 1,500 watts, **£7**; 1,000 watts, **£5.**

H.T. TRANSFORMER, in case, size 10 x 7 x 6 in. (no oil), 200v. to 10,000 volts, C./T. output; $2\frac{1}{2}$ KVA at 500 cycles, intermittent rating, **£8.**

METAL RECTIFIERS, size 5 x 4 $\frac{1}{2}$ x 4 $\frac{1}{2}$ ins., not Westinghouse, output 100 volts at 500 M/A, price **32/6**; ditto, 5 $\frac{1}{2}$ x 2 $\frac{1}{2}$ in., not Westinghouse, output 100 volt at 250 M/A, price **17/6**; ditto, output approx. 100 volt at 50 M/A, price **10/-**.

POWER TRANSFORMER, 4kW, double wound, 400 volts and 220 volts to 110 volts, 50 cycle, single phase. Price **£25.**

AMPLIFIER COMPONENTS, from dismantled American 10-watt amplifiers, all metal cased and compound filled. Input transformers, **15/-**; Interstage, **7/6**; Push-Pull input, **10/-**; Push-Pull output, **20/-**; Push-Pull output, **10/-**; Power Transformers, **12/6** and **25/-**; Capacitor Packs, **10/-** and **20/-**; Reactors, **12/6**; Audio Filters, **7/6**.

AUTO TRANSFORMER, step up or step down, 500 watts, tapped 0-110-200-220-240 volts **£3 10s.**

$\frac{1}{2}$ **WATT WIRE END RESISTANCES**, new and unused, price per doz. **5/-**, our assortment.

MOVING COIL AMPMETER by famous maker, 2 in. dia., flush mounting, reading 0-10 amps., F.S.D. 20 M/A, price **27/6**.

MOVING COIL VOLTMETER, 2 in. dia., flush mounting, dual range, reading 0-25 v. and 0-250 v, external resistance (supplied) is used for 250v. range, F.S.D. 5 M/A, price **55/-**.

SEARCHLIGHT by famous maker, size 22 in. dia., 18 in. deep, complete with cradle, reflecting mirror 20 in. dia., for electric bulb fitting, no bulb, adjustable focus, glass front, price **£7 10s.**

MOVING COIL AND M.I. METERS,
FOR FULL DETAILS OF ABOVE AND OTHER
GOODS, SEND FOR LIST, 2 $\frac{1}{2}$ d.

Class "C" Amplifiers—

the angle of flow of the Class "A" valve is thus 360 degrees. Secondly, emission occurs when anode and cathode are at widely

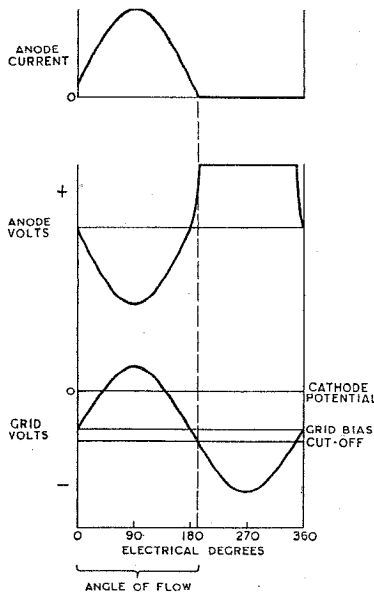

Fig. 6. The voltages through the valve and angle of flow in a Class "B" amplifier.

different potentials. In Fig. 6 is seen the performance of the Class "B" valve. The angle of flow is here 180, or a trifle more, degrees, and during emission the potential difference between anode and cathode is a good deal smaller than in Class "A." As Fig. 7 shows, the Class "C" valve carries both processes much farther. The angle of flow does not exceed 150 degrees and may be as little as 120. For the best

working conditions the maximum peak grid voltage should be equal to the minimum peak anode voltage. In a well-designed Class "C" amplifier the minimum peak anode voltage may be as low as 10 per cent. of the steady DC anode voltage and it should not exceed 20 per cent. It may be seen from Fig. 7 that maximum emission occurs when the anode potential is at its lowest with respect to the cathode and that the potential difference across the valve is then comparatively small.

Heat Dissipation

This last factor is of great importance. The greater the potential difference between anode and cathode, the greater is the speed attained by emitted electrons and therefore the more violent the impact on their arrival at the anode. Great speeds and violent impacts mean the generation of considerable heat, and heat at the anode is a totally undesirable product in a power amplifier. It has to be dissipated in some way—usually by a forced draught of air or by water cooling. Whatever method of dissipating unwanted heat is used, both installation and running costs have to be taken into account, and these may be far from small.

The Class "C" valve helps in the solution of the problem of heat dissipation in two ways: in the first place less heat is produced than in amplifiers of other classes owing to the lower speeds of electron travel; secondly, since the valve is passing anode current during only 120, or at most 150, out

of the 360 degrees of each grid voltage cycle, it is actually operating for only one-third or a little more of the total running time. During the remainder of the time it is cooling down by radiating the heat produced at its anode.

It will be realised that valves of given characteristics can be made to give a far higher power output

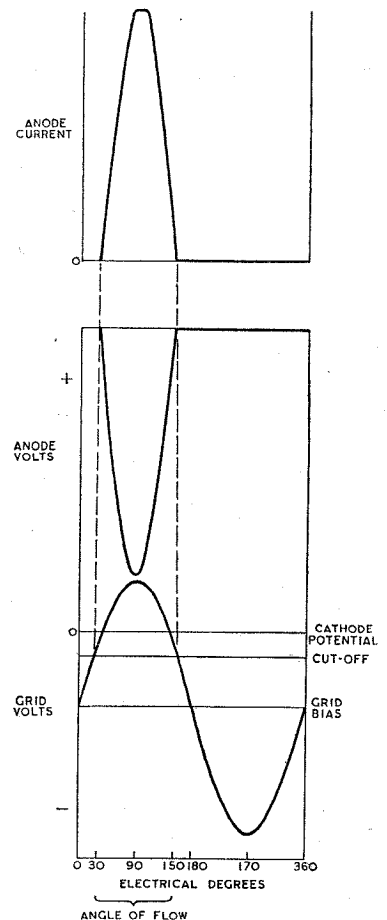

Fig. 7. The voltages through the valve and angle of flow in a Class "C" amplifier.

under Class "C" than under Class "A" conditions. Alternatively, for a given power output much smaller valves can be used if operated in Class "C" than would be possible if Class "A" working were employed.

Such then is the Class "C" amplifier. It has worked something like a revolution in the technique of radio transmission since its introduction, and it may play an even greater part in the developments that the future has in store.

Books issued in conjunction with "Wireless World"

	Net Price	By Post
FOUNDATIONS OF WIRELESS. Fourth Edition, by M. G. Scroggie	7/6	7/10
TELEVISION RECEIVING EQUIPMENT, by W. T. Cocking	10/6	10/10
RADIO LABORATORY HANDBOOK, by M. G. Scroggie. Second Edition	12/6	12/11
WIRELESS SERVICING MANUAL, by W. T. Cocking. Sixth Edition	7/6	7/10
HANDBOOK OF TECHNICAL INSTRUCTION FOR WIRELESS TELEGRAPHISTS, by H. M. Dowsett and L. E. Q. Walker. Seventh Edition	30/-	30/7
RADIO DATA CHARTS. Third Edition, Revised by J. McG. Sowerby, B.A., Grad. I.E.E.	7/6	7/10
RADIO INTERFERENCE SUPPRESSION, by G. W. Ingram	5/-	5/4
LEARNING MORSE. 335th thousand	6d.	7½d.
INTRODUCTION TO VALVES, by F. E. Henderson	5/-	5/4
RADIO WAVES AND THE IONOSPHERE, by T. W. Bennington	6/-	6/3

Obtainable from leading booksellers or by post from

LIFFE & SONS LTD., Dorset House, Stamford Street, London, S.E.1

WORLD OF WIRELESS

TRAINING OPPORTUNITY

A NEW full-time course in radio engineering, conducted under the Hankey scheme and lasting six months, is about to start at the Borough Polytechnic, Borough Road, London, S.E.1.

Students will ultimately sit for the Higher National Certificate in Radio Engineering, and, to qualify for admission to the course, should possess the Ordinary National Certificate in radio or electrical engineering, and some knowledge of radio communication. City and Guilds qualifications, with sufficient mathematics, will also qualify for admission.

As the course is starting at once, immediate application should be made by intending students.

RESTORING RUSSIAN RADIO

AS the Germans fell back before the Red Army's summer offensive, they systematically destroyed every kind of wireless equipment, paying special attention to the re-diffusion centres which are widely used in Russia for relaying broadcasting by wire to the inhabitants of towns and villages.

A special service was established by the Soviet Government for restoring radio services in the liberated territories, and skilled radio mechanics followed closely behind the army to carry out this task. Engineer A. Morozov, who has been in charge of restoration work, pays tribute to the ingenuity of his staff in improvising methods of repair, and proudly claims that in some localities the relay service has been put into working order on the same day as the Germans were driven out.

B.R.E.M.A.

THE British Radio Equipment Manufacturers' Association has been formed to take the place of the R.M.A. Equipment Makers' Section on the Radio Industry Council. The first meeting of the Association was held recently and the following officers were appointed:—Chairman, G. Darnley-Smith; Vice-Chairman, A. McVie; Trustees, E. K. Balcombe, L. D. Bennett and L. McMichael. The temporary address of the Association is at Century House, Shaftesbury Avenue, London, W.C.2 (Gerrard 7777). R. P. Browne is acting as Secretary for the time being.

A statement issued by the B.R.E.M.A. estimates that more than three million homes will need new receivers after the war and the industry is commencing to meet this demand with the provision of

250,000 standard sets during this year.

HIGHER AND HIGHER

WHAT are believed to be the highest frequencies allocated for specific communication purposes in the United States have been assigned to the American Telephone and Telegraph Company for experimental use.

Twelve frequency bands, varying in width from 11 to 23 Mc/s, between 1,914.04 Mc/s and 12,511.25 Mc/s have been granted to the company for a wide-band radio repeater circuit between New York and Boston. The proposed circuit will be capable of relaying FM, facsimile and television transmissions as well as telegraph and telephone communications.

It is planned to erect a number of repeater stations about 30 miles apart. The prototype will have a power of 10 watts.

SERVICING CERTIFICATE

FORTY-TWO candidates sat for the first examination for the Radio Servicing Certificate held by the Radio Trades Examination Board in London, Manchester and Glasgow in May. Nineteen entrants passed both the written and practical sections of the examination.

Details of the draft syllabus were published in our October, 1943, issue.

ARMY SIGNALS

READERS in the London area should take the opportunity of seeing the exhibition of Army Signals at Charing Cross underground station which is open daily until Oct. 1st. Features of the exhibition, which is staffed by R. Signals, include a communications diagram of an armoured division, in which there are 1,500 sets, and working exhibits of a morse training set and high-speed wireless telegraph apparatus.

WHAT THEY SAY

AMERICAN AMATEURS.—We had occasion a short while ago to suggest to F.C.C. that . . . they ought to set up machinery to issue amateur licences at the rate of about ten thousand a month for the first year or so after our resumption, with an easy hundred thousand hams by the end of the year and a quarter million in a few years.—*American Radio Relay League.*

PEACE ON EARTH.—If nations are to live in peace with one another . . . they must know and understand one another, and without freedom of communications such knowledge and



OUT OF THE BLACK EARTH

Nature has so planned it that out of black earth come beautiful flowers and the foods essential to our very sustenance. And so it is that from the darkness of the present hour . . . from the suffering and sacrifice of world war . . . will emerge a greater degree of understanding among men . . . more freedom for untold millions . . . and advanced ideas to make man's burdens lighter and life more enjoyable. Astatic, like so many other manufacturing concerns, has been broadened by the experience of war production, has employed its engineering skill and manufacturing facilities to create new products, the principles of which will be reflected in Astatic's commercial and civilian products of a new day.

ASTATIC

THE ASTATIC CORPORATION
YOUNGSTOWN, OHIO, U.S.A.
TORONTO, CANADA.

Exclusively Represented by
Frank Heaver Ltd. Kingsley Road,
Bideford, N. Devon

HOME SAFELY— THANKS TO RADIO



THE far reaching achievements of the electronics industry are being made available to the Armed Forces in ever increasing quantities.

Crowe is proud of its proven ability to produce precisely made electronic control mechanisms in large numbers.

★
Exclusively Represented by
Frank Heaver Ltd.,
Kingsley Road,
Bideford,
N. Devon.



CRONAME

RADIO COMPONENTS

CROWE NAME PLATE AND
MANUFACTURING CO.
CHICAGO, ILL. U.S.A.

World of Wireless—
understanding is impossible. . . .
Accordingly it is up to us now to
think and plan for a better world

communications system.—*J. L. Fly,*
chairman of the U.S. Federal Com-
munications Commission.
A FRESH START.—Television has

an opportunity given no other new
industry in all industrial history. It
has the opportunity to start afresh,
in the hiatus of war, and soundly

NEWS IN ENGLISH FROM ABROAD

Country : Station	Mc/s	Metres	Daily Bulletins (BST)	Country : Station	Mc/s	Metres	Daily Bulletins (BST)
Algeria				Egypt			
UNR (Algiers) ..	9.535 9.610	31.46 *31.21	0915, 1200, 1500* 1500*	Cairo	7.510	39.94	1845, 2100
America				French Equatorial Africa			
WLWK (Cincinnati) ..	6.080	49.34	0600, 0700	FZI (Brazzaville) ..	11.970	25.06	1945, 2145
WNRA (New York) ..	6.100	49.18	0500, 0600	India			
WOOC (Wayne) ..	6.120	49.03	0300, 0400, 0700, 0800	VUD3 (Delhi) ..	7.290	41.15	0800, 1300, 1550
WCBX (Brentwood) ..	6.170	48.62	0700	VUD4	9.590	31.28	0800, 1300, 1550
WGEX (Schenectady) ..	6.190	48.47	0300, 0400, 0500, 0600	VUD5	9.630	31.15	0800, 1550
WGEA (Schenectady) ..	7.000	42.86	0500, 0700	VUD6	11.790	25.45	0800
WGEO (Schenectady) ..	7.250	41.38	0700	VUD9	11.870	25.27	1550
WLWO (Cincinnati) ..	7.575	39.61	0600, 0700, 0800	VUD3	15.290	19.62	1300
WRUL (Boston) ..	7.805	38.44	0800	Iran			
WOOW (New York) ..	7.820	38.36	0300, 0700, 0800	EQB (Teheran) ..	6.155	48.74	2225
WCBN (New York) ..	9.490	31.61	0800	Mozambique			
WGEA (Schenectady) ..	9.530	31.48	0900, 1000, 1100, 1200	CR7BE (Lourenco Marques)	9.830	30.52	2050
WGEX (Schenectady) ..	9.550	31.41	0000, 0100, 2200, 2300	Newfoundland			
WBOS (Boston) ..	9.570	31.35	0900* 1000	VONH (St. John's) ..	5.970	50.25	2315
WCRC (New York) ..	9.590	31.28	0900, 1000	Palestine			
WOOC (New York) ..	9.650	31.09	0100, 0200	Jerusalem	11.750	25.53	1615
WNBI (New York) ..	9.670	31.02	0900, 1000, 1100, 1200	Portugal			
WRUW (Boston) ..	9.700	30.93	0800	CSW6 (Lisbon) ..	11.040	27.17	2000
WNRI (New York) ..	9.855	30.43	0100, 0200, 0300, 0400, 0700	Spain			
WLWO (Cincinnati) ..	11.710	25.62	2000,* 2100, 2200	EAQ (Aranjuez) ..	9.860	30.43	2050†
WRUW (Boston) ..	11.730	25.57	1300, 1400, 2000*	Sweden			
WCRC (Brentwood) ..	11.830	25.36	1200, 1430, 1530, 2000*	SBU (Motala) ..	9.535	31.46	2220
WGEA (Schenectady) ..	11.847	25.32	1900	SBP	11.705	25.63	1700
WGEX (Schenectady) ..	11.847	25.32	1100, 1200, 1300, 1400, 1500,* 1600	Switzerland			
WOOW (Wayne) ..	11.870	25.27	0100, 0200, 1300, 1630, 2100	HER3 (Schwarzenburg) ..	6.345	47.28	2050
WBOS (Boston) ..	11.870	25.27	1100	HER4	11.775	25.48	2050
WRCA (New York) ..	11.893	25.22	1000, 1100, 1200, 2000*	Syria			
WNRI (New York) ..	13.050	22.99	1200, 1300, 1500,* 1630, 2300	FXE (Beirut) ..	8.035	37.34	1735
WRUS (Boston) ..	15.130	19.83	1300, 1400, 1500,* 1600, 1700, 1800	Turkey			
WNBI (New York) ..	15.150	19.80	1500,* 2000*	TAP (Ankara) ..	9.465	31.70	1800
WOOC (Wayne) ..	15.190	19.75	1300, 1630, 2100	U.S.S.R.			
WBOS (Boston) ..	15.210	19.72	1300, 1400, 1500*	Moscow	6.980 7.300	42.98 41.10	0015 1800, 1900, 2000, 2100, 2200, 2300
WLWK (Cincinnati) ..	15.250	19.67	1400, 1500,* 1630, 1800, 1900, 2000,* 2100, 2200		7.322 8.940 9.480 9.860 10.445 11.830 11.950 12.190 12.260 15.040 15.230 15.570	40.92 33.56 31.65 30.43 28.72 25.36 25.11 24.61 24.47 19.85 19.70 19.05	1800 1240 0100, 0200 1240 0545, 1240 1600 0100, 0200, 2347 1240 1210 2347 2347 1300, 1340, 1420, 1700
WCBX (Brentwood) ..	15.270	19.65	1200, 1430, 1530, 2000,* 2045	Vatican City			
WGEO (Schenectady) ..	15.330	19.57	1300, 1400, 1630, 1800, 2000,* 2100	HVJ	5.970	50.25	2015
WRUW (Boston) ..	15.350	19.54	2000*	Algers		kc/s	Metres
WRUW (Boston) ..	17.750	16.90	1600, 1800		1,176	255	1200, 1500
WRCA (New York) ..	17.780	16.87	1500*	Athlone	565	531	1340, 1845, 2200* 2210†
WLWO (Cincinnati) ..	17.800	16.85	1300, 1400, 1500,* 1630, 1800, 1900	Tunis	823	365	0000, 2200, 2300
WCBN (New York) ..	17.830	16.83	1430, 1530, 2000*				
WGEX (Schenectady) ..	17.880	16.78	1900, 2100				
WNRA (New York) ..	18.160	16.52	1500,* 1630				
Australia							
VL14 (Sydney) ..	7.240	41.45	1515				
VLG (Melbourne) ..	9.580	31.32	1515				
Belgian Congo							
Leopoldville	15.167	19.78	1200				
Brazil							
PRL8 (Rio de Janeiro)	11.715	25.61	2030†				
China							
XGOY (Chungking) ..	9.635	31.14	1500, 1700, 2130				
Ecuador							
HCJB (Quito) ..	12.455	24.09	0000, 2030				

It should be noted that the times are BST—one hour ahead of GMT.

* Sundays only.

† Sundays excepted.

plan its own future. . . . Television before the war needed a shade more technical improvement, and most engineers agree that in this war it is getting it.—“*Fortune*” Magazine.

IN BRIEF

Naval Scientists.—Engineers and research workers in the various experimental and development sections of the Admiralty have now been embodied in a new organisation—the Royal Naval Scientific Service. This purely civilian service will be under the control of C. S. Wright, Director of Scientific Research.

New Wavelength.—The B.B.C.’s transmission for the Allied Expeditionary Force is now being radiated on 514.6 metres (583 kc/s) instead of 285.7 metres. The new wavelength has allocated to France under the Lucerne Plan and was used by the P.T.T. station Alpes-Grenoble.

Far Eastern War News.—In preparation for the expected increase in news when the war against Japan is intensified, a high-power radio transmitter has been opened at the headquarters of the 14th Army, from which messages sent by war correspondents on the Far Eastern front will be received in London within a few minutes. A second transmitter is being installed in Ceylon, and when this is ready the two transmitters will be capable of handling 160,000 words a day.

Alternative Route Open.—To provide an alternative route for transmission of messages from London to Australia, Cable and Wireless have now opened a new wireless relay station at Colombo, Ceylon. The station is for use when the direct London-Australia beam is unusable, due either to magnetic disturbances or overcrowding.

Awards to Radio Officers.—First Radio Officer H. W. H. Norcliffe has been made a Member of the Order of the British Empire as a commendation for great courage shown by him in endeavouring to extinguish the fires which raged in his ship after it had been torpedoed. Senior Radio Officer R. Stewart and Chief Radio Officer J. V. Watson sacrificed their lives when they remained at their sets to send out distress signals as their ships sank. They have been posthumously awarded the Lloyd’s War Medal for bravery at sea.

U.S. and India.—Negotiations by the British and Indian Governments have resulted in the opening of a new direct radio telegraph circuit between United States and India.

Press Traffic Record.—The twelfth week of the Battle of France, in which the liberation of Paris took place, resulted in a new high record of Press wordage handled by Cable and Wireless, a total of 1,988,290 words being forwarded by them to all parts of the world.

Brit.I.R.E.—Owing to the cancellation of the annual general meeting of the Brit.I.R.E., arranged for September 1st, Leslie McMichael, the president-elect, will deliver his presidential address at the meeting of the Midland Section on September 27th at the Imperial Hotel, Birmingham.

Institution of Electronics.—At a meeting of the North-West Branch of the Institution to be held at 6.30 on October 27th, 1944, at the Reynolds Hall, College of Technology, Manchester, Dr. J. A. Darbyshire will lecture on Hot Cathode Mercury Vapour Rectifiers. Non-members may obtain tickets from L. F. Berry, 14, Heywood Avenue, Austerlands, Oldham, Lancs.

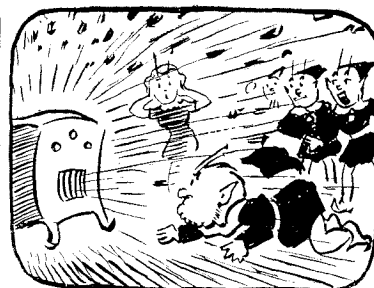

THE “FLUXITE QUINS” AT WORK

“This set’s the real thing, I’ll declare
You can almost imagine you’re there.
Hear the guns mighty roar” . . .
Then cried EH from the floor,
“What that set needs is FLUXITE, I’ll swear!”

See that FLUXITE is always by you — in the house — garage — workshop — wherever speedy soldering is needed. Used for over 30 years in Government works and by leading engineers and manufacturers. Of all Iron-mongers—in tins, 8d., 1/4 & 2/8.

Ask to see the FLUXITE SMALL-SPACE SOLDERING SET—compact but substantial—complete with full instructions, 7/6.

TO CYCLISTS! Your wheels will NOT keep round and true unless the spokes are tied with fine wire at the crossings AND SOLDERED. This makes a much stronger wheel. It’s simple—with FLUXITE—but IMPORTANT.

The FLUXITE GUN puts FLUXITE where you want it by a simple pressure. Price 1/6, or filled, 2/6.



ALL MECHANICS WILL HAVE

FLUXITE
IT SIMPLIFIES ALL SOLDERING

Write for Book on the ART OF “SOFT” SOLDERING and for Leaflets on CASE-HARDENING STEEL and TEMPERING TOOLS with FLUXITE. Price 1d. each.

FLUXITE LTD.
Dept. W.W.), Bermondsey Street, S.E.1

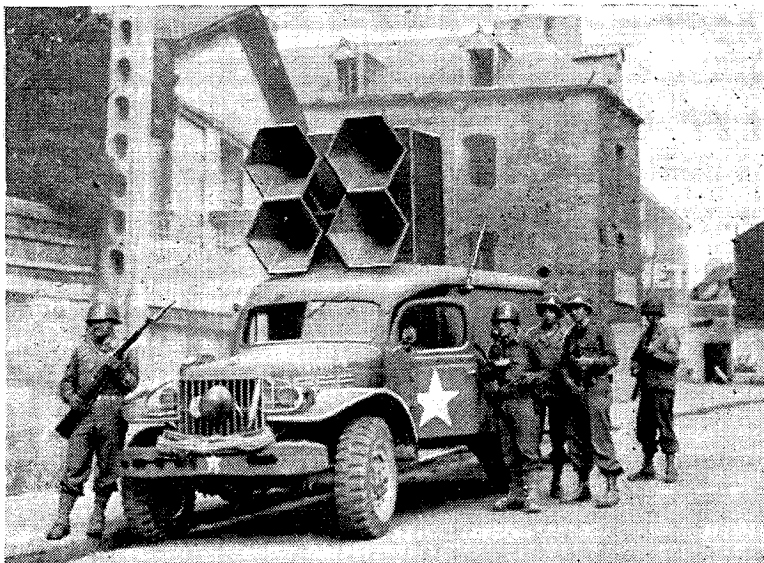

FRONT LINE P.A. During the battle of France the Allied Forces made considerable use of public address equipment. In addition to giving instructions to the inhabitants of the towns and villages it has been employed by the U.S. Army in its psychological warfare. This photograph, taken in St. Malo, shows Americans calling on snipers to surrender.

BAIRD "TELECHROME"

Cathode-Ray Colour and Stereoscopic Television Receiver

THE difficulties of research and development under wartime conditions have not sufficed to deter Mr. J. L. Baird from his pursuit of a commercially practicable stereoscopic colour television system. Between 1941 and 1943 he demonstrated three optical projection methods of transmitting pictures in colour and three dimensions,* each of which was a noteworthy step forward in quality and realism but suffered from the limitations either of being restricted to individual viewers, involving the use of revolving shutters or lacking brilliance through loss of light in filters.

All these objections have been successfully overcome in his latest system, termed the "Telechrome," in which the picture is viewed directly on the screen of a cathode-ray tube as in conventional television receivers. The fluorescent screen is a thin mica disc coated on both sides and mounted inside a spherical bulb. One side is coated with blue-green and the other with orange-red fluorescent material and two cathode-ray beams from "guns" sealed into opposite sides of the containing bulb provide separate excitation for the back and front surfaces.

* See *Wireless World*, February, 1942 and February 1943.



With this type of cathode-ray tube, in which the picture may be viewed on both sides of the screen, the potential size of the audience is doubled.

The transmitter employs 600-line triple-interlaced scanning and a revolving disc interposes orange-red and blue-green filters for alternate frames. The 3:2 relationship between colour and frames ensures that large areas of any one colour do not show line striations. At the receiver the two colour elements combine to give a picture in natural colour, which, in one form of tube can be viewed from both sides, though one group of viewers in this case get a reverse image of the original scene.

By scanning alternate frames through the mirror system described in this journal dated February, 1942, and viewing the

resultant displaced images through spectacles with the corresponding colour filters for the left and right eye, excellent stereoscopic depth of vision is obtained. Colour can be combined with stereoscopic vision in this system by further breaking up each frame into colour elements, but the resultant picture is in the nature of a compromise and it would seem that for the time being it would be better to use either colour or stereoscopic effects separately according to the nature of the programme material.

Advantages of the present system are that it does not call for a wider frequency band than that used in pre-war television transmissions; and the non-stereoscopic pictures can be received in monochrome on existing television receivers.

Given a wider channel width the system could

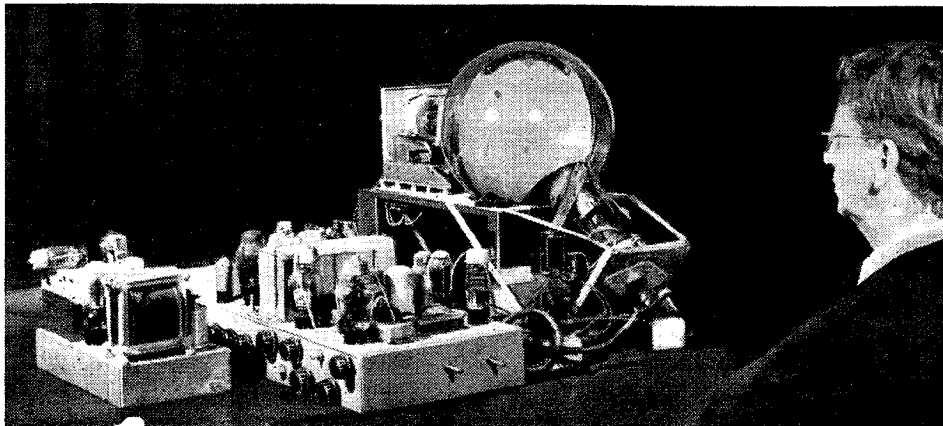

Complete receiving equipment showing tube designed for viewing from one side only.

Baird "Telechrome"—
be extended to use three colour
elements by using a screen of
transparent plastic material with

front surface, as in the two-colour
system.

Another improvement in course
of development is a scanning

Schematic arrange-
ment of cathode-
ray tubes used in
the Baird "Tele-
chrome" system ;
(a) two-colour, (b)
three-colour.

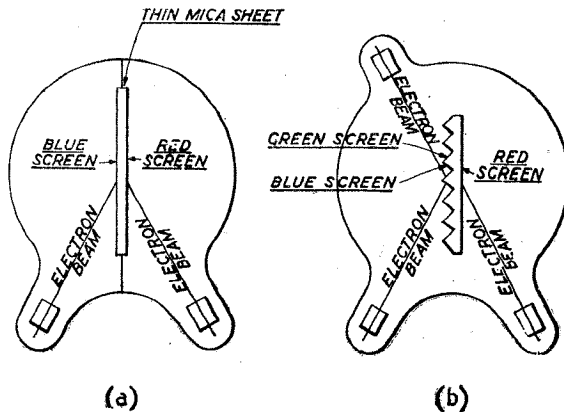

a series of parallel ridges moulded
in the back surface. One side of
each ridge would then be coated
with green and the other with
blue fluorescent material, the red
coating being used for the plane

system in which successive lines
instead of successive frames are of
different colours. If the number
of lines is made a non-multiple of
the number of colours, all traces
of flicker should be removed.

BOOK REVIEW

Physics and Radio. By M. Nelkon,
B.Sc. Pp. 388 + XIII; 507 figures.
Edward Arnold and Co., 41,
Maddox Street, London, W.1.

IN this book the author has given
an account of the fundamental
physical principles of radio. The
book has an unusual but attrac-
tively wide scope, and in addition
to the usual sections on Ohm's law,
inductance, capacitance, tuned cir-
cuits and AC theory, there are
chapters on magnetism and electro-
magnetism, electrolysis, electro-
statics, light, sound and the mecha-
nism of propagation; in each the
author has carefully pointed out the
connection between the subject and
radio. In the chapter on sound, for
example, useful comparisons are
drawn between the stationary sound
waves in an organ pipe and
stationary electromagnetic waves in
aerial wires. In Chapter XXIV the
similarity between the refraction of
light in glass and the bending of
electromagnetic waves in the iono-
sphere is pointed out.

The work on valves and circuits
generally is straightforward: there
are chapters on basic principles of
valves, the triode, the tetrode and
pentode, the valve as a voltage
amplifier, the valve as an oscillator
and the power output stage. It is
always easy to find apparent omis-
sions in books such as this which
cover such a vast amount of know-

ledge in a comparatively small
amount of text, but there seems no
doubt that this book would have
been improved by the inclusion of
some circuit diagrams of complete
"straight" receivers and amplifiers.
Similarly, the inclusion of some
mention of the superheterodyne
principle would, in view of its wide-
spread application, have been an
advantage. Apart from these omis-
sions there is little to criticise.
Some may claim, in Chapter I, that
it is illogical to lead off with
"effects of an electric current" on
p. 1, and to define a current as an
electron flow on p. 4.

Each chapter closes with a sum-
mary of the most important points
contained in it and a set of exer-
cises, descriptive and numerical in
character. Answers to the numerical
exercises are given at the end of the
book. Too few books have been
written with the aim of emphasising
the physical background of radio,
and Mr. Nelkon is to be congratu-
lated on making this excellent
attempt to fill the gap. S. W. A.

GOODS FOR EXPORT

The fact that goods made of
raw materials in short supply
owing to war conditions are
advertised in this journal should
not be taken as an indication
that they are necessarily available
for export.

VORTEXION

50 WATT

AMPLIFIER CHASSIS

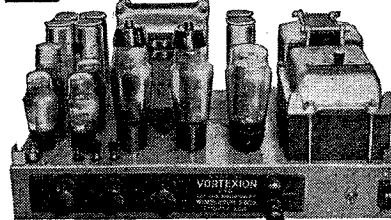

The new Vortexion 50 watt
amplifier is the result of over
seven years' development with
valves of the 6L6 type. Every
part of the circuit has been care-
fully developed, with the result
that 50 watts is obtained after
the output transformer at ap-
proximately 4% total distortion.
Some idea of the efficiency of the
output valves can be obtained
from the fact that they draw
only 60 ma. per pair no load, and
160 ma. full load anode current.
Separate rectifiers are employed
for anode and screen and a
Westinghouse for bias.

The response curve is straight
from 200 to 15,000 cycles in the
standard model. The low fre-
quency response has been pur-
posely reduced to save damage
to the speakers with which it
may be used, due to excessive
movement of the speech coil.

A tone control is fitted, and the large eight-
section output transformer is available to
match, 15-60-125-250 ohms. These output
lines can be matched using all sections of
windings, and will deliver the full response to
the loud speakers with extremely low overall
harmonic distortion.

PRICE (with 807, etc. type valves) **£18.10.0**
Plus 25% War Increase

MANY HUNDREDS ALREADY IN USE
Supplied only against Government Contracts

VORTEXION LTD.
257, THE BROADWAY,
WIMBLEDON, S. W. 19.
Phone: LIBerty 2814

"AESTHETICS OF SOUND REPRODUCTION"

Replies to Readers' Queries and a Postscript

THE following notes are intended to deal with most of the points raised by correspondence arising from the article under the above title in the July and August issues of this journal. It is hoped that the information given will avoid the necessity of letters having to be written and answered on technical matters.

A number of readers require information on the 3-henry air-cored choke. Fig. 1 gives a simplified version of the original design suitable for amateur construction. The coil former is an assembly of five $3\frac{1}{2}$ in. diameter laminated bakelite discs $\frac{1}{8}$ in. thick, spaced by four $1\frac{1}{2}$ in. diameter discs $\frac{1}{4}$ in. thick. These latter could be hardwood, ebonite or the like. The whole is held together by a 2BA stud and nuts, and large washers should be used against the outside cheeks to support them. The former is then wound full with 40 SWG enamelled wire. Taps are conveniently brought out at the end of each

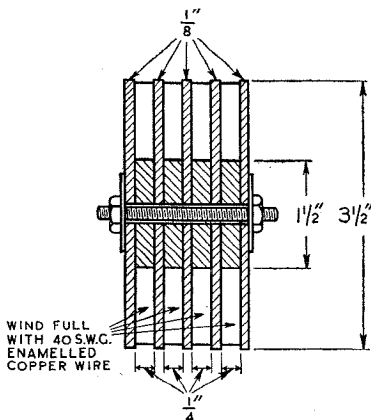

Fig. 1. Constructional details of a 3H choke, suitable for amateur construction, which can be relied upon to give good results in the circuit described in the original article.

section. It will be appreciated that the first slot should be filled, then the second, and so on.

A suitable control unit external

By H. A. HARTLEY

to the cabinet is indicated in Fig. 2. The components shown are mounted on a small metal panel, and the back of the panel and the components are enclosed in a moderately substantial screening box. The various leads connecting the controls to the radiogram are of good-quality single-way screened flexible wire, the screening braiding being bonded at each end, and used as the earth return. The leads can be up to about 6ft. long without noticeably impairing the performance of the complete instrument. Such an external control box is very convenient, and well worth the trouble of making carefully. The components are numbered to agree with the numbers on the complete circuit diagram which appeared in the August issue.

At this point it might be as well to clear up one or two obvious errors or omissions which found their way into the original article. In the circuit (Fig. 3) on page 237 of the August issue a blocking condenser should be inserted between the "Radio" contact of S1 and the junction of L2 and C16 to keep DC out of the coupling transformer primary and to preserve the correct DC cathode load in the detector stage. In my set this condenser has a value of $0.5 \mu\text{F}$. The current rating of the 5-volt heater winding for the rectifiers should be 4 amps., not 2 amps., as stated in the list of component values. On page 236 (last line but one of first

paragraph) the rejector circuit should be L1C9, and in line 16 of the third column, the grid circuit referred to should be V1, not V9.

I am sorry that I cannot undertake to offer critical comments on readers' equipment. Such requests do really miss the point of my contribution, which was to express a point of view on musical reproduction. My argument was

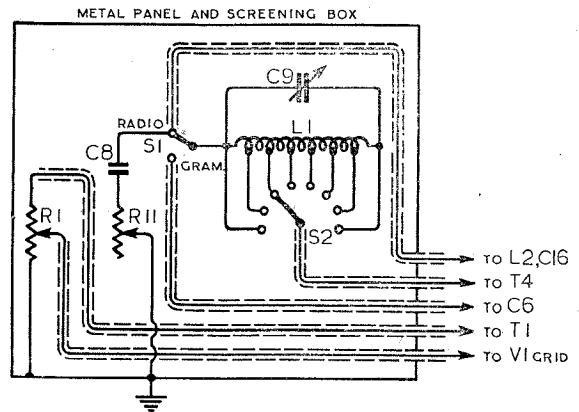

Fig. 2. Screening arrangements required when rejector circuit is mounted outside the cabinet as a remote control unit. C9 must be insulated from panel.

that "high fidelity" was not enough, and I gave a slightly philosophical thesis on the artistic reproduction of music. In the course of my argument I pointed out that the basis was equipment capable of reproducing all frequencies equally between 32 and 10,000 cycles per second, and purely as a matter of convenience to my readers I gave a description of an instrument which I had designed myself as a basis for my experiments. My contribution is not a "constructional article," and the description of my own radiogram is not an essential part of my thesis. In these difficult times I just have no idea where the various special bits and pieces can be obtained. To get my own instrument completed I had to exercise all the guile I could muster, and I can

only recommend my readers to do likewise.

Choosing records is not quite such a pig-in-a-poke as it used to be, provided certain points are borne in mind. Nearly all the records of American orchestras are poor recordings in varying degrees. This, apparently, is due to the fact that American radiograms are all bottom and no top, so the records are all top and no bottom. Unfortunately, this cannot be remedied by cutting top and boosting bass, for the top is so distorted and scratchy as to be painful. "Attack" is poor, and the piano sounds like a cross between a harpsichord and a banjo. On the other hand, new English

cordings are good and sometimes superb. H.M.V. records numbered C3000 and upwards, and Columbia DX1000 and upwards are generally a safe buy, and no doubt certain Decca records are equally good, but I have not tried them on my own machine. The British Council H.M.V. records are all good, and Dr. Sargent and the Liverpool Philharmonic Orchestra, and Barbirolli with the Hallé Orchestra on Columbia have mastered the art of making records. I can specially recommend Dohnanyi's "Variations on a Nursery Tune" (Col. DX1148-1150) and Ireland's "London Overture" (Col. DX1155-1156). The fill-up on the latter work is Johann Strauss' "Radetzky March," which has the most amazing bass drum recording I have ever heard. An extraordinarily impressive record, and a certain favourite if you want to show that your speaker is "the real thing," and you don't suffer from "boom."

BRIT.I.R.E. GRADUATESHIPS

OF the eighty-eight candidates who sat for the May, 1944, graduateship examination of the British Institution of Radio Engineers, eighteen were successful. The examination was held in fourteen centres in Great Britain and abroad and, for the first time, in a prisoner-of-war camp in Germany.

It is understood a few overseas papers have not yet arrived.

The examiners state that although the papers showed considerable improvement on previous examinations in physics and the specialist subject, the majority of candidates failed to obtain adequate marks in radio engineering.

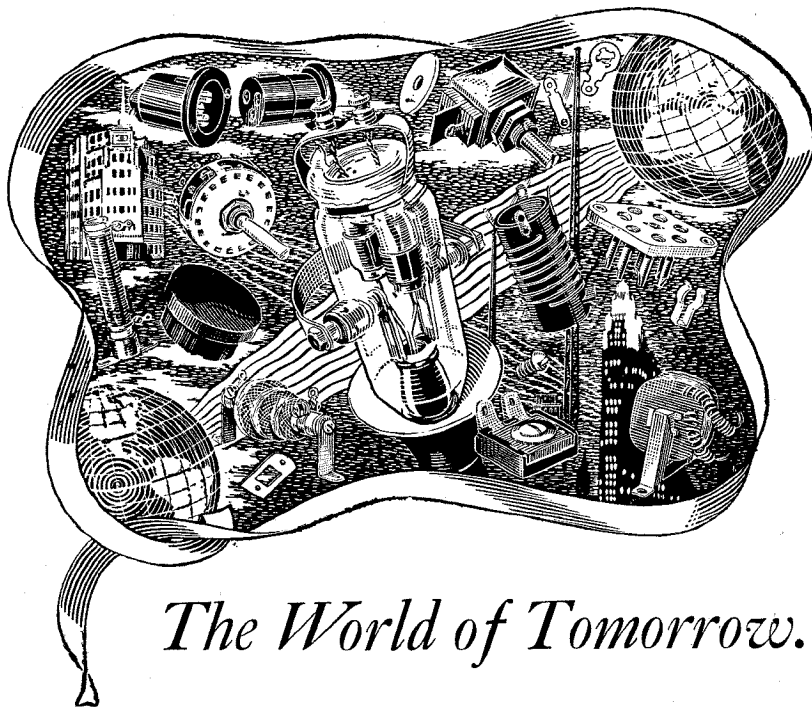

The World of Tomorrow.

JUST as the reliability and ingenuity of BULGIN RADIO PRODUCTS have been proved in the stress of War, so in the World of Tomorrow Industry can safely trust us with their component problems and requirements.

The return of Peace will find us ready to ease a large part of your production difficulties. Our technique, with a background of 21 years of experience solely devoted to the manufacture of essential components, will safeguard your trade mark.

(Please quote priority and Contract Nos.)

"The Choice of Critics"

BULGIN

Registered Trade Mark

A. F. BULGIN & CO. LTD., BYE PASS RD., BARKING, ESSEX
Radio and Electrical Component Manufacturers.
TEL. : RIPPLEWAY 3474 (5 lines).

PERMEABILITY TUNING

THE outer surface of the sliding core S of a variable tuning inductance L is partly covered with longitudinal strips P of thin conducting material. This serves to increase the inherent capacity between the windings of the coil as the core S is moved inwards, and, by reducing its natural frequency, to increase the effective tuning range of a coil having a given ratio of length to diameter.

The total shunt capacity, indicated by C, also includes the grid-cathode capacity of the input valve V, which tends to lessen the full effect of the strips P; it is therefore better to connect the grid of the valve to an intermediate point along the coil, instead of

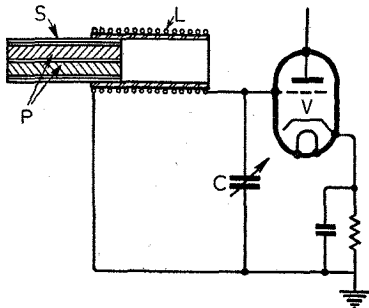

Permeability tuner.

to the end as shown. In practice the capacity C is supplemented by a small variable condenser for fine tuning.

The strips P tend to prevent the magnetic flux from leaving the powdered-iron core except at its end; they also tend to cut down the intensity of the electric field inside the core, and so reduce dielectric losses. It is stated that the overall tuning range can be still further enlarged by connecting the strips P at one end to a common lead, which is earthed.

Marconi's Wireless Telegraph Co., Ltd. (Assignees of W. van B. Roberts). Convention date (U.S.A.) July 30th, 1941. No. 559718.

RADIO COURSE INDICATORS

THE particular quadrant in which a pilot may find himself when flying to or from a radio beacon is indicated, without ambiguity, by using an auxiliary trio of directive aerials, set at right angles to the first, for radiating some of the distinctive signals.

The main aerial system radiates two overlapping beams, one carrying a 90-cycle and the other a 150-cycle note, whilst the auxiliary aerials are supplied, through a reversing switch, with the usual A-N signals superposed on a 1,000-cycle frequency. The carrier frequency is radiated only by the centre dipole of the main aerial, the other dipoles of the system being fed through balanced modulators with the sideband components only of their respective signals.

The resulting space-pattern surrounding the beacon is then such that the NW quadrant is dominated by 90 cycles and the A-signal; the NE quadrant by

A Selection of the More Interesting Radio Developments

90 cycles and the N-signal; the SW quadrant by 150 cycles and the A-signal; and the SE quadrant by 150 cycles and the N-signal.

Standard Telephones and Cables, Ltd. (assignees of A. Alford). Convention date (U.S.A.) December 17th, 1941. No. 560364.

PHOTO-ELECTRIC CELLS

THE active surface of a selenium or copper-oxide cell is deliberately ribbed or corrugated, or otherwise made non-planar, in order to increase the effective area of contact, and therefore the response of the cell, to light rays which arrive at right angles to its general plane. Alternatively, by making the corrugations saw-toothed, or similarly asymmetric in cross-section the cell can be made to give maximum response to rays which arise either at a selected angle to the normal or from a given direction in azimuth.

The selenium is laid over a thick metal base-plate and its upper surface is shaped or corrugated by a suitably cut die. An outer coating of translucent metal, only a few molecules thick, is then sputtered over the selenium and over a thick peripheral rim of metal, which forms the second current-collecting electrode. As the translucent coating is of high resistance a few radial grooves are formed in the non-planar surface in order to provide straight paths of minimum resistance for currents flowing from the centre of the cell to the rim electrode.

Sangamo Weston, Ltd. Convention date (U.S.A.) April 3rd, 1942. No. 560652.

REPRODUCTION IN COLOUR

NATURAL colour effects are reproduced by interposing between the object and a primary recording device (such as a photographic negative) a filtering system which consists of a light polariser and analyser placed on opposite sides of a disc of birefringent material, such as regenerated cellulose. For a four-colour system, this disc is divided into equal quadrants, each of which has a different thickness and molecular orientation from its neighbour. The projected light is thus split up, by the different refractive elements, into four spatially displaced images, which respectively contain, say, the red, green, yellow and blue colour contents of the original picture.

By rotating the optical system, the spatial distribution of the colours can be varied in a cyclic sequence.

For reproduction, a similar optical system, synchronised with the first, is interposed between the primary record and the viewing screen. The invention is described as applied to coloured

cinematography, but is stated to be equally applicable to television, in which case the "primary record" is the electric image formed on the mosaic screen of a cathode-ray transmitter.

B. T. Hewson and A. Locan. Application date August 13th, 1942. No. 561425.

SHORT-WAVE AERIALS

AN aerial with omnidirectional properties, say in the horizontal plane, consists of a pair of sheet conductors wound spirally to form a double ramp about a vertical mast, which also serves as a coaxial feeder. One edge of the spiral sheet A is connected to the outer tube B of the mast, whilst the sheet A1 is similarly attached to the inner coaxial line B1, passing through insulated slots (not shown) cut in the outer tube. Parts of the spiral surfaces which are separated in space by a quarter-wavelength are thus energised in phase-quadrature. The figure illustrates one complete spiral of an assembly which may comprise several such turns in series.

In effect, the aerial is generated by rotating a half-wave dipole and simultaneously moving it along the vertical mast. The directional response is therefore the sum of an infinite number of

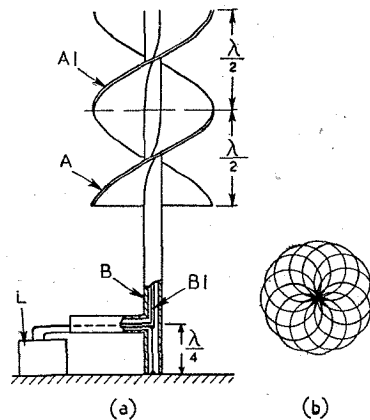

(a) (b)
Omnidirectional aerial.

figure-of-eight loops, thus producing an omnidirectional effect.

The transmitter or receiver L is coupled to the mast at a point a quarter-wavelength above the earth. This allows the base of the mast to be grounded as a safeguard against lightning.

Standard Telephones and Cables, Ltd. (assignees of A. B. Bailey). Convention date (U.S.A.) November 8th, 1941. No. 560271.

The British abstracts published here are prepared with the permission of the Controller of H.M. Stationery Office, from specifications obtainable at the Patent Office, 25, Southampton Buildings, London, W.C.2, price 1/- each.